

City of Clinton

Meetings

September 1, 2020



PUBLIC NOTICE OF MEETING
REGULAR MEETING OF CLINTON AIRPORT AUTHORITY
TUESDAY, SEPTEMBER 1, 2020
CLINTON CITY HALL

5:30 P.M.

AGENDA

- 1. Call to Order**
- 2. Opening Prayer/Pledge Pat Peters, Church of Christ**
- 3. Consent Agenda**
 - A. Consider approval of Minutes of August 4, 2020**
 - B. Consider claims**
- 4. Action Items:**
- 5. Trustee's Report**
- 6. City Manager's Report**
- 7. Adjournment**

Filed this _____ day of _____, 2020.

Posted on the bulletin board in the lobby of the Clinton City Hall on
_____, 2020, _____ A.M./P.M.

Debra Blanchard, Acting City Clerk

**MINUTES OF AIRPORT AUTHORITY MEETING
AUGUST 4, 2020**

Minutes of the regular meeting of the Chairman and Trustees of the Clinton Airport Authority City of Clinton, Oklahoma, Custer County, held in the City Council Room, City Hall on Tuesday, August 5, 2020, at 5:30 p.m. A notice of this meeting with agenda was posted on the bulletin board in the lobby of Clinton City Hall on Friday, July 31, 2020.

Chairman David Berrong called the meeting to order with the following present;

CHAIRMAN: David Berrong

TRUSTEES: Patch McComas, Ernie Dowdell, Bobby Stewart, Chris Jones

ACTING CITY MANAGER: Gene McCullough

CITY TREASURER: Debra Blanchard

CITY ATTORNEY: Ryan Meacham

DEPUTY TREASURER: Shona Stermer

NEWS MEDIA: Rod Serfoss and Mike Smith

OTHERS: Paul Rinkel, Donnie Phipps, Gary Kluckner, Pat Peters, Rhonda Williams

Pat Peters opened the meeting with prayer and Trustee Bobby Stewart led the Pledge of Allegiance.

AGENDA ITEM NO. 3: CONSENT AGENDA

- A. Minutes of Regular Meeting of July 7, 2020
- B. Consider claims

Moved by Trustee Jones and seconded by Trustee Dowdell, that Consent Agenda Item No. 3 (a-b) be approved.

Chairman put the motion to a roll call vote:

Aye: Jones, Dowdell, Stewart, McComas, Berrong

Nay: None

Chairman declared the motion carried.

AGENDA ITEM NO. 4 ACTION ITEMS

None

AGENDA ITEM NO. 5 TRUSTEES REPORT

None

AGENDA ITEM NO. 6: CITY MANAGER'S REPORT

None

AGENDA ITEM NO. 7: AUDIENCE PARTICIPATION

None

AGENDA ITEM NO. 8: ADJOURNMENT

AA080420

Moved by Trustee Dowdell and seconded by Trustee Jones to adjourn the meeting.

Chairman put the motion to a roll call vote:

Aye: Dowdell, Jones, Stewart, McComas, Berrong

Nay: None

Chairman declared the meeting adjourned at 5:33 p.m.

FUND: GENERAL FUND

DEPARTMENT	VENDOR NAME	GL ACCOUNT	ACCOUNT DESCRIPTION	DESCRIPTION	AMOUNT
NON-DEPARTMENTAL	OK TAX COMMISSION	2405	SALES TAX LIABILITY	OK TAX COMMISSION	87.88
		2405	SALES TAX LIABILITY	SALES TAX BAL DUE JULY 20	67.08
		500-54010	SWIMMING POOL COLLEC	SALES TAX BAL DUE JULY 20	3.02
	C.L.E.E.T.	2600	DUE TO STATE - CLEET	PENALTY ASSESSMENT FEES JU	985.65
	O.S.B.I.	2600	DUE TO STATE - CLEET	O.S.B.I.	1,864.33
	MISCELLANEOUS V EMILY THOMAS	500-54090	FACILITY/PROPERTY RE	EMILY THOMAS:RFND PAVILLIO	25.00
	OK UNIFORM BUILDING CODE COM	2601	DUE TO STATE-OUBCC R	OUBCC FEES FOR JULY 2020	124.00
	OKLAHOMA BUREAU OF NARCOTIC	2602	DUE TO STATE - OBN D	DRUG EDUCATION FEES JULY20	20.00
				TOTAL:	3,176.96
GOVERNING BOARD	BRITTAIN & ASSOCIATES INC	40100-2030	LIABILITY INSURANCE	RNWL CRIME PROTECTION BOND	775.00
	ACTION ASSOCIATES INC	40100-2650	CONTRIBUTION TO OTHE	AGREEMENT FOR SERVICES FY2	20,000.00
	RS MEACHAM CPAs & ADVISORS P	40100-2095	FINANCIAL AUDIT	FIN CONSULTANT FYE6/	950.00
				TOTAL:	21,725.00
ADMINISTRATION	MIDWEST FARMERS INC	40200-2425	FUEL, OIL, ETC.	FUEL USE	40.05
	OK EMPLOYMENT SECURITY COMMI	40200-1095	UNEMPLOYMENT COMPENS	UNEMPLOYMENT BNFTS 2ND QTR	1,228.92
	OK MUN. ASSURANCE GROUP	40200-1090	WORKERS' COMPENSATIO	WORKERS COMP 2020/2021 1ST	3,227.19
	CLINTON AUTO GLASS INC	40200-2045	VEHICLE REPAIR & MAI	DETAIL 2013 FORD ESCAPE	150.00
	RONDENA WILLIAMS	40200-2120	CONTRACTUAL SERVICES	120.45 HOURS CONTRACT LABO	2,409.00
	MARGARET MCMORROW-LOVE	40200-2085	PROFESSIONAL SERVICE	INTERVIEWS/EMAILS/TEL CONF	1,144.50
				TOTAL:	8,199.66
FINANCE	OK MUN. ASSURANCE GROUP	40300-1090	WORKERS' COMPENSATIO	WORKERS COMP 2020/2021 1ST	2,358.32
	KIWANIS CLUB OF CLINTON, OK	40300-2605	DUES, SUBSCRIPTIONS,	CIVIC DUES JULY20 BLANCHAR	40.00
	RS MEACHAM CPAs & ADVISORS P	40300-2085	PROFESSIONAL SERVICE	941 & CARES ACT ASSISTANCE	250.00
	PITNEY BOWES	40300-2010	POSTAGE	POSTAGE REFILL	69.00
	INFOSEND, INC	40300-2120	CONTRACTUAL SERVICES	BILLING FOR AUG2020	1,821.66
				TOTAL:	4,538.98
LEGAL AND COURTS	OK MUN. ASSURANCE GROUP	40400-1090	WORKERS' COMPENSATIO	WORKERS COMP 2020/2021 1ST	701.00
				TOTAL:	701.00
POLICE ADMINISTRATION	DEPT OF PUBLIC SAFETY	40501-2110	RENTAL CHARGES	LEASE OLETS EQUIP SYSTEM	350.00
	OK MUN. ASSURANCE GROUP	40501-1090	WORKERS' COMPENSATIO	WORKERS COMP 2020/2021 1ST	1,314.25
	VERIZON	40501-2005	TELEPHONE	6 MONTHS PREPAYMENT 5 HOTS	1,200.30
	WEX BANK dba WRIGHT EXPRESS	40501-2425	FUEL, OIL, ETC.	FUEL USE	112.01
				TOTAL:	2,976.56
POLICE SUPPORT SERVICE	OK MUN. ASSURANCE GROUP	40502-1090	WORKERS' COMPENSATIO	WORKERS COMP 2020/2021 1ST	2,625.40
				TOTAL:	2,625.40
POLICE OPERATIONS	OK MUN. ASSURANCE GROUP	40503-1090	WORKERS' COMPENSATIO	WORKERS COMP 2020/2021 1ST	6,492.27
	GUARDIAN SECURITY SYSTEMS, I	40503-2410	OPERATING SUPPLIES	ALARM MONITORING PD	19.50
	MISCELLANEOUS V AUSTIN TROGD	40503-2421	PARTS-VEHICLE MAINTN	AUSTIN TROGDON:BULD PCARD	24.99
	WEX BANK dba WRIGHT EXPRESS	40503-2425	FUEL, OIL, ETC.	FUEL USE	1,861.20
				TOTAL:	8,397.96
POLICE ANIMAL CONTROL	OK MUN. ASSURANCE GROUP	40504-1090	WORKERS' COMPENSATIO	WORKERS COMP 2020/2021 1ST	491.81
	WEX BANK dba WRIGHT EXPRESS	40504-2425	FUEL, OIL, ETC.	FUEL USE	237.77
				TOTAL:	729.58
FIRE ADMINISTRATION	OK MUN. ASSURANCE GROUP	40601-1090	WORKERS' COMPENSATIO	WORKERS COMP 2020/2021 1ST	1,159.62
	AMERICAN LEGION H.O.P. 41	40601-2470	FACILITIES MAINTENAN	AMERICAN FLAG/OKLAHOMA FLA	111.00

FUND: GENERAL FUND

DEPARTMENT	VENDOR NAME	GL ACCOUNT	ACCOUNT DESCRIPTION	DESCRIPTION	AMOUNT
				TOTAL:	1,270.62
FIRE PROTECTION	OK MUN. ASSURANCE GROUP	40606-1090	WORKERS' COMPENSATIO	WORKERS COMP 2020/2021 1ST	5,913.23
	RED DIRT WIRELESS	40606-2470	FACILITIES MAINTENAN	TOWER SPEAKERS FIRE DEPART	300.00
	WEX BANK dba WRIGHT EXPRESS	40606-2425	FUEL, OIL, ETC.	FUEL USE	864.56
				TOTAL:	7,077.79
EMERGENCY MGMT	PUBLIC SERVICE CO OF OK dba	40607-2456	STORM SIREN MAINT &	ELECTRIC SERVICE/ALL DEPTS	34.65
				TOTAL:	34.65
INSPECTION	OK MUN. ASSURANCE GROUP	41000-1090	WORKERS' COMPENSATIO	WORKERS COMP 2020/2021 1ST	555.42
	ARTHUR C GRAVES	41000-2092	NUISANCE ABATE/CONTR	ABATEMENT MOWING 513 N 3RD	50.00
		41000-2092	NUISANCE ABATE/CONTR	ABATEMENT MOWING	75.00
		41000-2092	NUISANCE ABATE/CONTR	ABATEMENT MOWING 618 N 17T	75.00
		41000-2092	NUISANCE ABATE/CONTR	ABATEMENT MOWING 20TH & WE	60.00
		41000-2092	NUISANCE ABATE/CONTR	ABATEMENT MOW 17TH & DOUGH	60.00
		41000-2092	NUISANCE ABATE/CONTR	ABATEMENT MOWING 605 S 13T	20.00
		41000-2092	NUISANCE ABATE/CONTR	ABATEMENT MOWING 516 S 12T	45.00
		41000-2092	NUISANCE ABATE/CONTR	ABATEMENT MOW 300 JIM ROBB	30.00
		41000-2092	NUISANCE ABATE/CONTR	ABATEMENT MOW 740 GLENN SM	50.00
		41000-2092	NUISANCE ABATE/CONTR	ABATEMENT MOWING 518 N 13T	75.00
	OK FLOODPLAIN MGMT ASSOC	41000-2615	TRAINING & DEVELOPME	OFMA CONFERENCE	100.00
		41000-2605	DUES, SUBSCRIPTIONS,	OFMA CFM RENEWAL	25.00
		41000-2605	DUES, SUBSCRIPTIONS,	OFMA MEMBERSHIP	50.00
	MARIO E COUTINO	41000-2092	NUISANCE ABATE/CONTR	600 N 18TH 7/1 8/4 8/19/20	140.00
		41000-2092	NUISANCE ABATE/CONTR	1807 HUNT 7/1 8/4/20	140.00
		41000-2092	NUISANCE ABATE/CONTR	505 N 8TH 7/1 8/4/20	75.00
		41000-2092	NUISANCE ABATE/CONTR	510 N 13TH 7/1 8/4/20	115.00
		41000-2092	NUISANCE ABATE/CONTR	320 S 14TH 7/1 8/5/ 8/19/2	150.00
		41000-2092	NUISANCE ABATE/CONTR	1618 NEPTUNE 7/1 8/5/ 8/19	270.00
		41000-2092	NUISANCE ABATE/CONTR	517 GLENN SM 7/14 8/5 8/19	130.00
	WEX BANK dba WRIGHT EXPRESS	41000-2425	FUEL, OIL, ETC.	FUEL USE	69.15
				TOTAL:	2,359.57
PARKS MAINTENANCE	OKLAHOMA NATURAL GAS CO	41108-2080	NATURAL GAS CHARGES	NATURAL GAS SERVICE	37.28
	OK MUN. ASSURANCE GROUP	41108-1090	WORKERS' COMPENSATIO	WORKERS COMP 2020/2021 1ST	547.82
	STEVE WEAVER	41108-2120	CONTRACTUAL SERVICES	DEWINTERIZE MCR & ACME BAT	236.45
	PROFESSIONAL TURF PRODUCTS L	41108-2120	CONTRACTUAL SERVICES	MOWER REPAIR	636.00
	PUBLIC SERVICE CO OF OK dba	41108-2075	ELECTRIC CHARGES	ELECTRIC SERVICE/ALL DEPTS	955.02
		41108-2075	ELECTRIC CHARGES	ELECTRIC SERVICE/ALL DEPTS	1,387.68
	JEFF BAILEY ELECTRIC, LLC	41108-2120	CONTRACTUAL SERVICES	RPR PARKING LOT LTS ACME	697.06
	28 RENTALS, LLC	41108-2110	RENTAL CHARGES	TLT MINI GF/SOCCER	270.00
		41108-2110	RENTAL CHARGES	TOILET KLUMP PARK	100.00
	WEX BANK dba WRIGHT EXPRESS	41108-2425	FUEL, OIL, ETC.	FUEL USE	506.37
				TOTAL:	5,373.68
SWIMMING POOL	OKLAHOMA NATURAL GAS CO	41109-2080	NATURAL GAS CHARGES	NATURAL GAS SERVICE	37.28
	OK MUN. ASSURANCE GROUP	41109-1090	WORKERS' COMPENSATIO	WORKERS COMP 2020/2021 1ST	547.81
	PUBLIC SERVICE CO OF OK dba	41109-2075	ELECTRIC CHARGES	ELECTRIC SERVICE/ALL DEPTS	1,301.00
	JEFF BAILEY ELECTRIC, LLC	41109-2046	EQUIPMENT REPAIR & M	RPRS MAIN START PUMP POOL	224.96
				TOTAL:	2,111.05
STREETS MAINTENANCE	CIRCLE S PAVING CO INC	41208-2485	STREET REPAIR & MAIN	TYPE C ASPHALT STREET REPA	700.70
	OK MUN. ASSURANCE GROUP	41208-1090	WORKERS' COMPENSATIO	WORKERS COMP 2020/2021 1ST	1,008.28

FUND: GENERAL FUND

DEPARTMENT	VENDOR NAME	GL ACCOUNT	ACCOUNT DESCRIPTION	DESCRIPTION	AMOUNT
	PUBLIC SERVICE CO OF OK dba	41208-2076	STREET LIGHTING CHAR	ELECTRIC SERVICE/ALL DEPTS	6,948.51
	WEX BANK dba WRIGHT EXPRESS	41208-2425	FUEL, OIL, ETC.	FUEL USE	156.46
				TOTAL:	<u>8,813.95</u>
RECREATION	OK STATE DEPT OF HEALTH	41408-2605	DUES, SUBSCRIPTIONS,	LIC20-93478 ACME CONCESSIO	125.00
	OKLAHOMA NATURAL GAS CO	41408-2080	NATURAL GAS CHARGES	NATURAL GAS SERVICE	189.02
	OK MUN. ASSURANCE GROUP	41408-1090	WORKERS' COMPENSATIO	WORKERS COMP 2020/2021 1ST	815.60
	CITY OF CLINTON	41408-2060	WATER CHARGES	WATER BILL ACME BRICK PARK	24.41
		41408-2065	SEWER CHARGES	SEWER BILL ACME BRICK PARK	18.79
		41408-2460	MISCELLANEOUS	FEES ACME BRICK PARK	10.70
	PUBLIC SERVICE CO OF OK dba	41408-2075	ELECTRIC CHARGES	ELECTRIC SERVICE/ALL DEPTS	2,021.69
		41408-2075	ELECTRIC CHARGES	ELECTRIC SERVICE/ALL DEPTS	1,130.54
	PITNEY BOWES	41408-2010	POSTAGE	POSTAGE REFILL	69.00
	WEX BANK dba WRIGHT EXPRESS	41408-2425	FUEL, OIL, ETC.	FUEL USE	67.12
				TOTAL:	<u>4,471.87</u>
CEMETERY	OK MUN. ASSURANCE GROUP	41600-1090	WORKERS' COMPENSATIO	WORKERS COMP 2020/2021 1ST	832.37
	WEX BANK dba WRIGHT EXPRESS	41600-2425	FUEL, OIL, ETC.	FUEL USE	81.56
				TOTAL:	<u>913.93</u>
FACILITIES MAINTENANCE	ARTIC AIR REFRIG. INC.	41700-2130	FACILITIES REPAIR		850.00
	OKLAHOMA NATURAL GAS CO	41700-2080	NATURAL GAS CHARGES	NATURAL GAS SERVICE	569.75
	OK MUN. ASSURANCE GROUP	41700-1090	WORKERS' COMPENSATIO	WORKERS COMP 2020/2021 1ST	127.82
	GUARDIAN SECURITY SYSTEMS, I	41700-2120	CONTRACTUAL SERVICES	ALARM MONITORING LIBRARY	29.00
		41700-2120	CONTRACTUAL SERVICES	ALARM MONITORING EASTSIDE	24.50
	STEVE WEAVER	41700-2120	CONTRACTUAL SERVICES	UNSTOP DRAIN AT CITY HALL	120.00
	PUBLIC SERVICE CO OF OK dba	41700-2075	ELECTRIC CHARGES	ELECTRIC SERVICE/ALL DEPTS	227.32
		41700-2075	ELECTRIC CHARGES	ELECTRIC SERVICE/ALL DEPTS	6,968.76
	SHRED-IT USA INC.	41700-2120	CONTRACTUAL SERVICES	PAPER RECYCLING 7/20-6/21	100.00
	SYMMETRY ENERGY SOLUTIONS, L	41700-2080	NATURAL GAS CHARGES	NATURAL GAS SERVICE	9.48
	JEFFERSON JANITORIAL SERVICE	41700-2120	CONTRACTUAL SERVICES	JANITORIAL AGREEMENT	3,200.00
		41700-2120	CONTRACTUAL SERVICES	JANITORIAL PD	720.00
	TROY & BANKS, INC.	41700-2080	NATURAL GAS CHARGES	UTILITY AUDIT ONG ACCOUNTS	22.48
				TOTAL:	<u>12,969.11</u>

FUND: CAPITAL IMPROVEMNT

DEPARTMENT	VENDOR NAME	GL ACCOUNT	ACCOUNT DESCRIPTION	DESCRIPTION	AMOUNT
ADMINISTRATION	CDW GOVERNMENT INC	40200-3010	OFFICE FURNITURE/EQU	NEW COMPUTERS & MONITORS	251.07
		40200-3010	OFFICE FURNITURE/EQU	NEW COMPUTERS & MONITORS	3,735.69
				TOTAL:	<u>3,986.76</u>
FINANCE	CDW GOVERNMENT INC	40300-3010	OFFICE FURNITURE/EQU	NEW COMPUTERS & MONITORS	418.45
		40300-3010	OFFICE FURNITURE/EQU	NEW COMPUTERS & MONITORS	6,226.15
				TOTAL:	<u>6,644.60</u>
POLICE OPERATIONS	CDW GOVERNMENT INC	40503-3030	OTHER EQUIPMENT	LAPTOP MOUNTS PD	702.30
		40503-3030	OTHER EQUIPMENT	NEW COMPUTERS & MONITORS	83.69
		40503-3030	OTHER EQUIPMENT	NEW COMPUTERS & MONITORS	1,245.23
				TOTAL:	<u>2,031.22</u>
FIRE PROTECTION	CDW GOVERNMENT INC	40606-3010	OFFICE FURNITURE/EQU	NEW COMPUTERS & MONITORS	167.38
		40606-3010	OFFICE FURNITURE/EQU	NEW COMPUTERS & MONITORS	2,490.46
				TOTAL:	<u>2,657.84</u>
PARKS MAINTENANCE	DEERE CREDIT, INC	41108-4005	DEBT SERVICE - PRINC	LEASE PYMNT 2 JD MOWERS	932.58
		41108-4005	DEBT SERVICE - PRINC	LEASE PYMNT 2 JD MOWERS	932.58
				TOTAL:	<u>1,865.16</u>
STREETS MAINTENANCE	OK DEPT OF TRANSPORTATION	41208-3035	IMPROVEMENTS OTHER T	I40B WASHITA RIVER BRIDGE	80,340.35
				TOTAL:	<u>80,340.35</u>
COMMUNITY REHAB PROJ	ROOTS 66 SOD FARM	43300-3035	IMPROVEMENTS OTHER T	SOD FOR MCR PLAYGROUND	1,920.00
				TOTAL:	<u>1,920.00</u>

FUND: HOUSING/HOPE VI FUND

DEPARTMENT	VENDOR NAME	GL ACCOUNT	ACCOUNT DESCRIPTION	DESCRIPTION	AMOUNT
HOUSING-HOPE VI MAIN S	OKLAHOMA NATURAL GAS CO	44900-2080	NATURAL GAS CHARGES	NATURAL GAS SERVICE	33.15
	GUARDIAN SECURITY SYSTEMS, I	44900-2120	CONTRACTUAL SERVICES	ALARM MONITORING HOPE APT	24.50
	PUBLIC SERVICE CO OF OK dba	44900-2075	ELECTRIC CHARGES	ELECTRIC SERVICE/ALL DEPTS	156.00
	JEFFERSON JANITORIAL SERVICE	44900-2120	CONTRACTUAL SERVICES	SWEEP HOPE STAIRWAY	50.00
				TOTAL:	<u>263.65</u>

FUND: PUBLIC WORKS AUTHORI

DEPARTMENT	VENDOR NAME	GL ACCOUNT	ACCOUNT DESCRIPTION	DESCRIPTION	AMOUNT
NON-DEPARTMENTAL	SINOR EMERGENCY MEDICAL	2306	DUE TO SEMS/AMBULANC	AMBULANCE FEE COLLECTED JU	18,680.68
	BANCFIRST	1122	CASH - BOND ACCT 201	PAYMENT TO 2014 PWA BOND A	147,210.95
		1122	CASH - BOND ACCT 201	TRUSTEE FEE	166.67
				TOTAL:	166,058.30
WATER ADMINISTRATION	FOSS RESERVOIR M.C.D.	40701-2210	FOSS ASSESSMENT	MTHLY ASSESSMENT PER AGREE	80,610.93
	OK MUN. ASSURANCE GROUP	40701-1090	WORKERS' COMPENSATIO	WORKERS COMP 2020/2021 1ST	419.50
	ENVIROTECH SERVICES INC	40701-2224	Oil & Gas Related Ex	PROFESSIONAL SVRS 6/28-7/3	1,115.00
		40701-2224	Oil & Gas Related Ex	PROFESSIONAL SVRS 6/28-7/3	1,532.00
	CDW GOVERNMENT INC	40701-3010	OFFICE FURNITURE/EQU	NEW COMPUTERS & MONITORS	83.69
		40701-3010	OFFICE FURNITURE/EQU	NEW COMPUTERS & MONITORS	1,245.23
	AMERICAN MUNICIPAL SERVICES	40701-2120	CONTRACTUAL SERVICES	UTILITY COLLECTIONS JUNE 2	152.65
	RS MEACHAM CPAs & ADVISORS P	40701-2095	FINANCIAL AUDIT	FIN CONSULTANT FYE6/	375.00
	PITNEY BOWES	40701-2010	POSTAGE	POSTAGE REFILL	68.99
	CANUTE PUBLIC WORKS AUTHORIT	40701-2213	CANUTE WATER PURCHA	RAW WATER PURCHASE JULY202	25,588.95
	BURNS & MCDONNELL ENGINEERIN	40701-2090	ENGINEERING & ARCHIT	TO16 WS HIGH TOWER MAINT	47,506.00
		40701-2090	ENGINEERING & ARCHIT	TO16 WS HIGH TOWER MAINT	3,767.00
	WEX BANK dba WRIGHT EXPRESS	40701-2425	FUEL, OIL, ETC.	FUEL USE	206.05
	OFFICE OF NATURAL RESOURCES	40701-2225	ROYALTIES PAID	TRIBAL ROYALTY PAID JJ SMI	110.00
	ENABLE MIDSTREAM PARTNERS	40701-2224	Oil & Gas Related Ex	NET REVENUE JJ SMITH/HEARD	46.13
	HAMM & PHILLIPS SERVICE CO,	40701-2224	Oil & Gas Related Ex	HAUL FLUID TO DISPOSAL	278.50
		40701-2224	Oil & Gas Related Ex	PU LW & DELIVER SWD 178019	278.50
	SYNERGY ENERGY SUPPLY, LLC	40701-2224	Oil & Gas Related Ex	COUPLING/THREADED BULL PLU	68.42
				TOTAL:	163,452.54
	WATER MAINTENANCE	OKLAHOMA NATURAL GAS CO	40708-2080	NATURAL GAS SERVICE	NATURAL GAS SERVICE
OK MUN. ASSURANCE GROUP		40708-1090	WORKERS' COMPENSATIO	WORKERS COMP 2020/2021 1ST	879.29
PUBLIC SERVICE CO OF OK dba		40708-2075	ELECTRIC CHARGES	ELECTRIC SERVICE/ALL DEPTS	4,653.19
		40708-2075	ELECTRIC CHARGES	ELECTRIC SERVICE/ALL DEPTS	186.01
2-D TRAILER SALES		40708-3030	OTHER EQUIPMENT	TILT-TRAILER - MINI EXCAVA	8,700.00
JEFF BAILEY ELECTRIC, LLC		40708-2120	CONTRACTUAL SERVICES	ELECTRIAL RPRS FOSS PUMP S	1,092.64
		40708-2120	CONTRACTUAL SERVICES	WSH TOWER RPLC BALLAST/LAM	1,053.07
REED SERVICES UNLIMITED, LLC		40708-2130	FACILITIES REPAIR	TROUBLE CALL FOSS PUMP STA	680.00
		40708-2120	CONTRACTUAL SERVICES	RPR AIR NETWORK WHS TOWER	4,029.48
		40708-2120	CONTRACTUAL SERVICES	RPR AIR NETWORK CANYON W T	2,752.50
		40708-2130	FACILITIES REPAIR	RPC BYPASS CONTRACTOR	1,987.64
		40708-2130	FACILITIES REPAIR	FOSS PUMP STN INTEGRATOR R	7,999.90
		40708-2120	CONTRACTUAL SERVICES	RPRS TO KOA PUMP SYSTEM	1,857.08
LONEHICKORY CATTLE LLC		40708-2120	CONTRACTUAL SERVICES	REPLACE WATER VALVE ACME	1,000.00
WEX BANK dba WRIGHT EXPRESS		40708-2425	FUEL, OIL, ETC.	FUEL USE	449.25
LEVI YOUNG		40708-2130	FACILITIES REPAIR	PUMP REPAIRS CLINTON LAKE	1,515.50
				TOTAL:	38,950.57
WATER TREATMENT	ARTIC AIR REFRIG. INC.	40710-3035	IMPROVEMENTS OTHER T	INSTALL NEW HVAC UNIT LAKE	10,500.00
		40710-2120	CONTRACTUAL SERVICES	RPR LENNOX UNIT CLINTON WT	738.20
	PUBLIC SERVICE CO OF OK dba	40710-2075	ELECTRIC CHARGES	ELECTRIC SERVICE/ALL DEPTS	1,480.72
	JEFF BAILEY ELECTRIC, LLC	40710-2120	CONTRACTUAL SERVICES	HEATER THERMOSTAT RPRS WTP	323.41
	WATER HOLDINGS ACOUISITION,	40710-2120	CONTRACTUAL SERVICES	SRV/MAINT FEE WTP WWTP	35,897.46
		40710-2046	EQUIP REPAIR & MAINT	JUN/JUL20 LAB TESTING & SU	5,800.00
	REED SERVICES UNLIMITED, LLC	40710-2046	EQUIP REPAIR & MAINT	EMERGENCY RLC PLC EQUIP	14,994.79
			TOTAL:	69,734.58	
PRO WTR TREATMENT PLANT	ARTIC AIR REFRIG. INC.	40715-2120	CONTRACTUAL SERVICES	RPR DRAIN LINE MECH ROOM W	171.00
	PUBLIC SERVICE CO OF OK dba	40715-2075	ELECTRIC CHARGES	ELECTRIC SERVICE/ALL DEPTS	1,403.57

FUND: PUBLIC WORKS AUTHORI

DEPARTMENT	VENDOR NAME	GL ACCOUNT	ACCOUNT DESCRIPTION	DESCRIPTION	AMOUNT
				TOTAL:	<u>1,574.57</u>
WASTEWATER ADMINISTRAT	OK MUN. ASSURANCE GROUP	40801-1090	WORKERS' COMPENSATIO	WORKERS COMP 2020/2021 1ST	314.65
	RS MEACHAM CPAs & ADVISORS P	40801-2095	FINANCIAL AUDIT	FIN CONSULTANT FYE6/	375.00
	BURNS & MCDONNELL ENGINEERIN	40801-2090	ENGINEERING & ARCHIT	TO17 PROCESS FLOW DIAGRAM	5,241.06
		40801-2090	ENGINEERING & ARCHIT	TO15 INTERCEPTOR SEWER	889.00
				TOTAL:	<u>6,819.71</u>
WASTEWATER MAINTENANCE	OK MUN. ASSURANCE GROUP	40808-1090	WORKERS' COMPENSATIO	WORKERS COMP 2020/2021 1ST	879.29
	JEFF BAILEY ELECTRIC, LLC	40808-2120	CONTRACTUAL SERVICES	MOTOR RPRS WWTP	1,632.47
	WEX BANK dba WRIGHT EXPRESS	40808-2425	FUEL, OIL, ETC.	FUEL USE	449.25
				TOTAL:	<u>2,961.01</u>
WASTEWATER TREATMENT	BRENNTAG SOUTHWEST INC.	40810-2440	CHEMICALS	SULFUR DIOXIDE & CHLORINE	1,025.64
	PUBLIC SERVICE CO OF OK dba	40810-2075	ELECTRIC CHARGES	ELECTRIC SERVICE/ALL DEPTS	9,192.99
		40810-2075	ELECTRIC CHARGES	ELECTRIC SERVICE/ALL DEPTS	55.24
	WATER HOLDINGS ACOUISITION,	40810-2120	CONTRACTUAL SERVICES	SRV/MAINT FEE WTP WWTP	35,897.46
	COGENT, INC dba AUTOMATIC EN	40810-2120	CONTRACTUAL SERVICES	INSTALL FLYGT BASIN MIXER	11,837.82
				TOTAL:	<u>58,009.15</u>
2014 REV BOND ISSUE	BRITTAIN & ASSOCIATES INC	42700-3064	PROJ CONST - INJECTI	#87C003933 OBIA BOND RENEW	1,500.00
				TOTAL:	<u>1,500.00</u>

FUND: SOLID WASTE AUTHORITY

DEPARTMENT	VENDOR NAME	GL ACCOUNT	ACCOUNT DESCRIPTION	DESCRIPTION	AMOUNT
NON-DEPARTMENTAL	CITY OF CLINTON	1105	CASH IN DRAWER - SW	START UP CASH/SOL WST DROP	50.00
				TOTAL:	50.00
SOLID WASTE ADMINISTRATION	OK EMPLOYMENT SECURITY COMMISSION	40901-1095	UNEMPLOYMENT COMPENSATION	UNEMPLOYMENT BENEFITS 2ND QTR	872.93
	OK MUNICIPAL ASSURANCE GROUP	40901-1090	WORKERS' COMPENSATION	WORKERS COMP 2020/2021 1ST	436.38
	RS MEACHAM CPAs & ADVISORS PLLC	40901-2095	FINANCIAL AUDIT	FIN CONSULTANT FYE6/	375.00
				TOTAL:	1,684.31
SOLID WASTE COLLECTION	OKLAHOMA NATURAL GAS CO	40912-2080	NATURAL GAS CHARGES	NATURAL GAS SERVICE	40.08
	OK MUNICIPAL ASSURANCE GROUP	40912-1090	WORKERS' COMPENSATION	WORKERS COMP 2020/2021 1ST	3,201.97
	PRECISION FLAME CUTTING	40912-2426	PARTS - DUMPSTER REPAIR	50 DUMPSTER BOTTOMS & SHIP	5,910.00
	CITY OF CLINTON	40912-2060	WATER CHARGES	WATER BILL SHOP	24.41
		40912-2065	SEWER CHARGES	SEWER BILL SHOP	15.82
		40912-2460	MISCELLANEOUS	FEES SHOP	10.70
	REPUBLIC SERVICES	40912-2120	CONTRACTUAL SERVICES	SW DISPOSAL FEES JULY 2020	49,373.25
	PUBLIC SERVICE COMPANY OF OKLAHOMA dba	40912-2075	ELECTRIC CHARGES	ELECTRIC SERVICE/ALL DEPTS	58.80
		40912-2075	ELECTRIC CHARGES	ELECTRIC SERVICE/ALL DEPTS	316.13
	MISCELLANEOUS V DONNIE PHIPPS	40912-2420	TIRES, BATTERIES, ETC	DONNIE PHIPPS:ERROR ATWOOD	51.99
	WEX BANK dba WRIGHT EXPRESS	40912-2425	FUEL, OIL, ETC.	FUEL USE	3,003.09
				TOTAL:	62,006.24

FUND: CLINTON AIRPORT AUTH

DEPARTMENT	VENDOR NAME	GL ACCOUNT	ACCOUNT DESCRIPTION	DESCRIPTION	AMOUNT
NON-DEPARTMENTAL	WESTERN OKLA AVIATION, LLC	527-54020	GASOLINE/FUEL SALES	RIMBURSE OIL CC CHG/CALL O	193.88
				TOTAL:	193.88
AIRPORT	CDW GOVERNMENT INC	42700-3030	OTHER EQUIPMENT	NEW COMPUTERS & MONITORS	83.69
		42700-3030	OTHER EQUIPMENT	NEW COMPUTERS & MONITORS	1,245.23
	WESTERN OKLA AVIATION, LLC	42700-2142	MGMT FEE/FBO CONTRAC	FIXED BASE OPERATOR AGREE	6,548.97
	PUBLIC SERVICE CO OF OK dba	42700-2075	ELECTRIC CHARGES	ELECTRIC SERVICE/ALL DEPTS	935.08
	RS MEACHAM CPAs & ADVISORS P	42700-2095	FINANCIAL AUDIT	FIN CONSULTANT FYE6/	125.00
	WEX BANK dba WRIGHT EXPRESS	42700-2425	FUEL, OIL, ETC	FUEL USE	227.17
	ROGER K CATES dba CATES ENTE	42700-2050	RADIO REPAIR & MAINT	AWOS MAINT AGREEMENT CRA	300.00
				TOTAL:	9,465.14

FUND: RECREATION TRUST AUT

DEPARTMENT	VENDOR NAME	GL ACCOUNT	ACCOUNT DESCRIPTION	DESCRIPTION	AMOUNT	
NON-DEPARTMENTAL	OK TAX COMMISSION	2405	SALES TAX LIABILITY	OK TAX COMMISSION	1,597.94	
		2405	SALES TAX LIABILITY	SALES TAX BAL DUE JULY 20	718.90	
				TOTAL:	<u>2,316.84</u>	
GOLF COURSE ADMINISTRA	ROBERT LELAND ESSARY	41301-2110	RENTAL CHARGES	LAND RENT/PROBATE 8/24/20	300.00-	
		41301-2110	RENTAL CHARGES	LAND RENT COURSE	300.00	
	OKLAHOMA NATURAL GAS CO	41301-2080	NATURAL GAS CHARGES	NATURAL GAS SERVICE	39.77	
	OK EMPLOYMENT SECURITY COMMI	41301-1095	UNEMPLOYMENT COMPENS	UNEMPLOYMENT BNFTS 2ND QTR	6,869.53	
	OK MUN. ASSURANCE GROUP	41301-1090	WORKERS' COMPENSATIO	WORKERS COMP 2020/2021 1ST	365.21	
	GUARDIAN SECURITY SYSTEMS, I	41301-2120	CONTRACTURAL SERVICE	ALARM MONITORING PRO SHOP	35.00	
	CITY OF CLINTON	41301-2060	WATER CHARGES	WATER BILL GOLF COURSE	297.53	
		41301-2460	MISCELLANEOUS	FEES GOLF	10.70	
	PUBLIC SERVICE CO OF OK dba	41301-2075	ELECTRIC CHARGES	ELECTRIC SERVICE/ALL DEPTS	1,164.32	
		41301-2075	ELECTRIC CHARGES	ELECTRIC SERVICE/ALL DEPTS	583.56	
	BRIAN KENT MILLER	41301-2120	CONTRACTURAL SERVICE	GOLF COURSE MANAGEMENT AG	2,916.67	
		41301-2135	BANK SERVICE FEES	JUL 20 RMBRS VISA/MC FEES	444.19	
		41301-2135	BANK SERVICE FEES	JUN 20 RMBRSE VISA/MC FEES	442.28	
	DENNIS MCABEE DBA MCABEE'S S	41301-2410	OPERATING SUPPLIES	TITON VACUUM/2 BOXES BAGS	358.90	
	RS MEACHAM CPAs & ADVISORS P	41301-2095	FINANCIAL AUDIT	FIN CONSULTANT FYE6/	75.00	
	DAN DAY DBA PEACE CONTRACTOR	41301-2470	FACILITIES MAINTENAN	LIGHT BULBS PRO SHOP	237.00	
	28 RENTALS, LLC	41301-2110	RENTAL CHARGES	TOILET GOLF COURSE	90.00	
		41301-2110	RENTAL CHARGES	TOILET NS OF GC	90.00	
	BRANDLEY INSPECTIONS, LLC	41301-2120	CONTRACTURAL SERVICE	WEED CONTROL	800.00	
	ROBERT LELAND ESSARY ESTATE	41301-2110	RENTAL CHARGES	LAND RENT GOLF COURSE	300.00	
				TOTAL:	<u>15,119.66</u>	
	GOLF COURSE MAINTENANC	OK MUN. ASSURANCE GROUP	41308-1090	WORKERS' COMPENSATIO	WORKERS COMP 2020/2021 1ST	1,819.27
			41308-2410	OPERATING SUPPLIES	O RINGS ANHD BED KNIVES	347.13
PROFESSIONAL TURF PRODUCTS L		41308-2422	PARTS - EQUIPMENT MA	O RINGS & BEARINGS	143.95	
BRANDLEY INSPECTIONS, LLC		41308-2120	CONTRACTURAL SERVICE	WEED CONTROL	800.00	
		BWI	41308-2439	FERTILIZERS	MAXTIMA FUNGICIDE	769.60
		41308-2440	CHEMICALS	PYLEX HERBICIDE	279.01	
			TOTAL:	<u>4,158.96</u>		
GOLF DEBT SRVC/DEPREC	PNC BANK, N.A. dba PNCEF, LL	41399-4005	DEBT SERVICE - PRINC	GOLF CART RENTAL LEASE	2,595.00	
		41399-4005	DEBT SERVICE - PRINC	LEASE PYMNT 2 JD MOWERS	932.58	
		41399-4005	DEBT SERVICE - PRINC	LEASE PYMNT 2 JD MOWERS	932.58	
	DEERE CREDIT, INC			TOTAL:	<u>4,460.16</u>	

FUND: CLINTON INDUSTRIAL A

DEPARTMENT	VENDOR NAME	GL ACCOUNT	ACCOUNT DESCRIPTION	DESCRIPTION	AMOUNT
NON-DEPARTMENTAL	MISCELLANEOUS V TYLER MARR	515-54051	EXHIBIT HALL	TYLER MARR:RFND FRISCO/COV	1,170.00
				TOTAL:	1,170.00
NON-DEPARTMENTAL	RS MEACHAM CPAs & ADVISORS P	40000-2095	FINANCIAL AUDIT	FIN CONSULTANT FYE6/	75.00
	KELSI SOUTH	40000-2120	CONTRACTUAL SERVICES	MONTHLY UPDATE TO WEBSITE	500.00
	CHARLES ALLEN ACKLEY	40000-2120	CONTRACTUAL SERVICES	MOWING ASSIGNED PROPERTIES	1,400.00
		40000-2120	CONTRACTUAL SERVICES	MOW ASSISGNEED PROPERTIES	1,450.00
		40000-2120	CONTRACTUAL SERVICES	MOWING ASSIGNED PROPERTIES	1,450.00
	WOODALL SERVICES, LLC	40000-2120	CONTRACTUAL SERVICES	MOWING ASSIGNED PROPERTIES	1,400.00
		40000-2120	CONTRACTUAL SERVICES	MOW & WEED EAT	1,325.00
				TOTAL:	7,600.00
CONF CTR OPERATION	ARTIC AIR REFRIG. INC.	41508-2130	FACILITIES REPAIR	DRAINED AC/CHECKED BLOWER	118.00
	CHAMBER OF COMMERCE	41508-2120	CONTRACTUAL SERVICES	FACILITIES MANAGEMENT AGR	8,000.00
	OKLAHOMA NATURAL GAS CO	41508-2080	NATURAL GAS CHARGES	NATURAL GAS SERVICE	133.02
	OK MUN. ASSURANCE GROUP	41508-1090	WORKERS' COMPENSATIO	WORKERS COMP 2020/2021 1ST	403.73
	CITY OF CLINTON	41508-2060	WATER CHARGES	WATER BILL CONF CENTER	24.41
		41508-2065	SEWER CHARGES	SEWER BILL CONF CENTER	15.82
		41508-2070	GARBAGE CHARGES	GARBAGE CHARGES CONF CENTE	153.40
		41508-2460	MISCELLANEOUS	FEES CONF CENTER	10.70
	JOHNSON SIGNS INC	41508-3035	IMPROVEMENTS OTHER T	CRANE TRUCK LIFT A/C UNIT	300.00
	PUBLIC SERVICE CO OF OK dba	41508-2075	ELECTRIC CHARGES	ELECTRIC SERVICE/ALL DEPTS	3,093.49
	RS MEACHAM CPAs & ADVISORS P	41508-2095	FINANCIAL AUDIT	FIN CONSULTANT FYE6/	75.00
	SYMMETRY ENERGY SOLUTIONS, L	41508-2080	NATURAL GAS CHARGES	NATURAL GAS SERVICE	15.16
	TROY & BANKS, INC.	41508-2080	NATURAL GAS CHARGES	UTILITY AUDIT ONG ACCOUNTS	22.48
				TOTAL:	12,365.21
LAND/COMM/INDUST DEV	PUBLIC SERVICE CO OF OK dba	45700-2075	ELECTRIC CHARGES	ELECTRIC SERVICE/ALL DEPTS	40.31
				TOTAL:	40.31

FUND: CLINTON HOSPITAL AUT

DEPARTMENT	VENDOR NAME	GL ACCOUNT	ACCOUNT DESCRIPTION	DESCRIPTION	AMOUNT
NON-DEPARTMENTAL	RS MEACHAM CPAs & ADVISORS P	40000-2095	FINANCIAL AUDIT	FIN CONSULTANT FYE6/	75.00
				TOTAL:	<u>75.00</u>

FUND: POOLED CASH

DEPARTMENT	VENDOR NAME	GL ACCOUNT	ACCOUNT DESCRIPTION	DESCRIPTION	AMOUNT
NON-DEPARTMENTAL	JP MORGAN CHASE BANK NA	2310	PCARD LIABILITY	CC PAYMENT 7/27/20 BILLING	70,068.94
				TOTAL:	70,068.94

===== FUND TOTALS =====

100	GENERAL FUND	98,467.32
430	CAPITAL IMPROVEMNT	99,445.93
520	HOUSING/HOPE VI FUND	263.65
700	PUBLIC WORKS AUTHORITY	509,060.43
710	SOLID WASTE AUTHORITY	63,740.55
720	CLINTON AIRPORT AUTHORITY	9,659.02
730	RECREATION TRUST AUTHOR.	26,055.62
740	CLINTON INDUSTRIAL AUTH.	21,175.52
770	CLINTON HOSPITAL AUTH.	75.00
999	POOLED CASH	70,068.94
----- GRAND TOTAL: -----		898,011.98

TOTAL PAGES: 13

SELECTION CRITERIA

SELECTION OPTIONS

VENDOR SET: 01-CITY OF CLINTON
VENDOR: All
CLASSIFICATION: All
BANK CODE: Include: FNBAP
ITEM DATE: 8/01/2020 THRU 8/28/2020
ITEM AMOUNT: 99,999,999.00CR THRU 99,999,999.00
GL POST DATE: 0/00/0000 THRU 99/99/9999
CHECK DATE: 0/00/0000 THRU 99/99/9999

PAYROLL SELECTION

PAYROLL EXPENSES: NO
EXPENSE TYPE: N/A
CHECK DATE: 0/00/0000 THRU 99/99/9999

PRINT OPTIONS

PRINT DATE: None
SEQUENCE: By Department
DESCRIPTION: Distribution
GL ACCTS: YES
REPORT TITLE: C O U N C I L R E P O R T
SIGNATURE LINES: 0

PACKET OPTIONS

INCLUDE REFUNDS: NO
INCLUDE OPEN ITEM:NO

FUND: GENERAL FUND

DEPARTMENT	VENDOR NAME	GL ACCOUNT	ACCOUNT DESCRIPTION	DESCRIPTION	AMOUNT
GOVERNING BOARD	CLINTON DAILY NEWS	40100-2630	COMMUNITY PROMOTION	BAR S APPREC PATRIOT SECT	368.82
				TOTAL:	368.82
ADMINISTRATION	CLINTON LAUNDRY AND CLEANERS	40200-2617	COVID 19 SUPPLIES/EX	CLEANING SUPPLIES	76.87
		40200-2617	COVID 19 SUPPLIES/EX	SOAP AND DISPENSERS	91.56
		40200-2617	COVID 19 SUPPLIES/EX	CLEANING SUPPLIES FOR ACME	439.44
	CLINTON DAILY NEWS	40200-2025	LEGAL PUBLICATIONS	ENOF YEAR NOTICE	29.86
	DOLLAR GENERAL CHARGED SA	40200-2617	COVID 19 SUPPLIES/EX	MASKS	70.00
	OK MUNICIPAL LEAGUE	40200-2605	DUES, SUBSCRIPTIONS,	2021MEMBERSHIP DUES ANDERS	68.50
	AT&T	40200-2005	TELEPHONE	VOICE OVER TELEPHONE	117.20
	AT&T MOBILTY	40200-2617	COVID 19 SUPPLIES/EX	FIRSTNET WIRELESS	179.75
		40200-2005	TELEPHONE	IPADS DATA PLANS	183.07
	O.S.B.I. (BACKGROUND CK)	40200-2616	EMPLOYEE HEALTH & SA	EUBANKS HUNTER URIBE BCKGR	45.00
		40200-2616	EMPLOYEE HEALTH & SA	HENSLEY PE BCKGRND CK	15.00
	DR. ROBERT BLAKEBURN	40200-2616	EMPLOYEE HEALTH & SA	BLAKEBURN CLINIC PD COVID	1,200.00
	SCHOONMAKER DRUG & ALCOHOL T	40200-2616	EMPLOYEE HEALTH & SA	HENSLEY PE DRUG SCREEN	45.00
		40200-2616	EMPLOYEE HEALTH & SA	COOK PE DRUG SCREEN	45.00
		40200-2616	EMPLOYEE HEALTH & SA	HUNTER PE DRUG SCREEN	45.00
		40200-2616	EMPLOYEE HEALTH & SA	URIBE PE DRUG SCREEN	45.00
		40200-2616	EMPLOYEE HEALTH & SA	EUBANKS PE DRUG SCREEN	45.00
	STAPLES ADVANTAGE	40200-2617	COVID 19 SUPPLIES/EX	FOREHEAD THERMOMETER PD	99.99
		40200-2405	OFFICE SUPPLIES	OFFICE GADGET	24.51
		40200-2617	COVID 19 SUPPLIES/EX	PURELL HAND SANITIZER	19.89
		40200-2617	COVID 19 SUPPLIES/EX	WALL TRAYS CH OFFICES COVI	150.10
		40200-2617	COVID 19 SUPPLIES/EX	PLASTIC LETTER WALL FILE	13.99
		40200-2405	OFFICE SUPPLIES	RETURN DAMAGED OFFICE GADG	24.51-
		40200-2617	COVID 19 SUPPLIES/EX	WALL FILE RETURN	13.99-
	VERIZON	40200-2005	TELEPHONE	ADMIN DATA	80.02
	INTERLINEBRANDS, INC. dba SU	40200-2617	COVID 19 SUPPLIES/EX	HAND SANITIZER	204.98
		40200-2617	COVID 19 SUPPLIES/EX	DISINFECTANT CLEANING SUPP	343.94
		40200-2617	COVID 19 SUPPLIES/EX	4 BXS NITRILE GLOVES	26.00
		40200-2617	COVID 19 SUPPLIES/EX	HAND SANITIZER	204.98
	EMPIRE PAPER	40200-2617	COVID 19 SUPPLIES/EX	4 GALLONS HAND SANITIZER	182.14
				TOTAL:	4,053.29
FINANCE	AT&T	40300-2005	TELEPHONE	VOICE OVER TELEPHONE	117.20
	AT&T MOBILTY	40300-2005	TELEPHONE	IPADS DATA PLANS	45.77
	STANDLEY SYSTEMS, LLC	40300-2040	OFFICE EQUIPMENT REP	PRINTER SERVICE AGREEMENT	42.30
	STAPLES ADVANTAGE	40300-2405	OFFICE SUPPLIES	TIME CARDS	11.04
		40300-2405	OFFICE SUPPLIES	COPY PAPER PAGE DIVDERS	148.15
	AMAZON.COM	40300-2405	OFFICE SUPPLIES	6 PACK RUBBER CEMENT	16.66
		40300-2405	OFFICE SUPPLIES	TW RIBBON CORRECTION TAPE	32.50
				TOTAL:	413.62
LEGAL AND COURTS	AT&T	40400-2005	TELEPHONE	VOICE OVER TELEPHONE	39.07
	STAPLES ADVANTAGE	40400-2405	OFFICE SUPPLIES	TIME CARDS	11.04
				TOTAL:	50.11
POLICE ADMINISTRATION	AT&T	40501-2005	TELEPHONE	BUSINESS LOCAL SERVICE	76.55
		40501-2005	TELEPHONE	BUSINESS LOCAL SERVICE	82.92
		40501-2005	TELEPHONE	VOICE OVER TELEPHONE	223.59
	AT&T MOBILTY	40501-2005	TELEPHONE	IPADS DATA PLANS	45.76
	US POSTAL SRVC	40501-2010	POSTAGE	RETURN DART GUN	34.14
	K & S TIRE INC	40501-2420	TIRES, BATTERIES, ET	TIRES U1	158.15

FUND: GENERAL FUND

DEPARTMENT	VENDOR NAME	GL ACCOUNT	ACCOUNT DESCRIPTION	DESCRIPTION	AMOUNT
	STANDLEY SYSTEMS, LLC	40501-2015	REPRODUCTION/PRINTIN	PRINTER SERVICE AGREEMENT	74.92
	CELLULAR NETWORK PARTNERSHIP	40501-2005	TELEPHONE	ON CALL CELL PHONE	36.22
	VERIZON	40501-2005	TELEPHONE	PD DATA	360.09
				TOTAL:	<u>1,092.34</u>
POLICE SUPPORT SERVICE	STANDLEY SYSTEMS, LLC	40502-2405	OFFICE SUPPLIES	PRINTER SERVICE AGREEMENT	119.91
	LANGUAGE LINE SERVICES, INC	40502-2405	OFFICE SUPPLIES	LANGUAGE LINE	10.16
				TOTAL:	<u>130.07</u>
POLICE OPERATIONS	BALLARD'S OF CLINTON INC	40503-2045	VEHICLE REPAIR & MAI	OIL CHANGE U30	54.95
		40503-2045	VEHICLE REPAIR & MAI	OIL CHANGE U13	58.00
	DOLLAR GENERAL CHARGED SA	40503-2431	PRISONER BOARDING	SUPPLIES JAIL	28.00
	GALL'S INC	40503-2435	UNIFORM SERVICE	SHIRT	58.94
	HAC, INC, DBA HOMELAND, UNIT	40503-2431	PRISONER BOARDING	GROC JAIL	80.40
		40503-2431	PRISONER BOARDING	GROC JAIL	488.78
		40503-2431	PRISONER BOARDING	GROC JAIL	637.05
	O'REILLY AUTOMOTIVE INC	40503-2421	PARTS-VEHICLE MAINT	AUTO DETAIL	47.95
	MISCELLANEOUS V MISCELLANEOU	40503-2425	FUEL, OIL, ETC.	QUICKTRIP GAS FUNERAL	24.17
	MISCELLANEOU	40503-2615	TRAINING & DEVELOPME	NATL ASSOC SCHOOL RS OFFIC	345.00
	MISCELLANEOU	40503-2615	TRAINING & DEVELOPME	SMITTY'S GARAGE	31.69
	MISCELLANEOU	40503-2410	OPERATING SUPPLIES	PD RADIO VC RECORDER SW	480.00
	K & S TIRE INC	40503-2045	VEHICLE REPAIR & MAI	OIL CHANGE	43.94
		40503-2045	VEHICLE REPAIR & MAI	OIL CHANGE	43.94
	C.O.P.S. PRODUCTS LLC	40503-2435	UNIFORM SERVICE	PANTS	242.90
		40503-2435	UNIFORM SERVICE	TIE	18.98
	STANDLEY SYSTEMS, LLC	40503-2015	REPRODUCTION/PRINTIN	PRINTER SERVICE AGREEMENT	465.63
	SKETCHSHE DESIGNS	40503-2435	UNIFORM SERVICE	HATS	230.00
	DANNY L. WATKINS dba CLINTON	40503-2045	VEHICLE REPAIR & MAI	OIL CHANGE AND BRAKES U4	275.37
				TOTAL:	<u>3,655.69</u>
POLICE ANIMAL CONTROL	ATWOODS	40504-2410	OPERATING SUPPLIES	SUPPLIES POUND	50.96
	PALMAR CAP-CHUR EQUIPMENT, I	40504-2410	OPERATING SUPPLIES	REPAIRS TO DART GUN	152.90
				TOTAL:	<u>203.86</u>
FIRE ADMINISTRATION	GALL'S INC	40601-2435	UNIFORM SERVICE	UNIFORM WHT SHRTS BR	155.96
	OK FIRE CHIEF ASSOC	40601-2605	DUES, SUBSCRIPTIONS,	OFCA DUE CHIEF	36.00
	AT&T	40601-2005	TELEPHONE	BUSINESS LOCAL SERVICE	85.65
		40601-2005	TELEPHONE	BUSINESS LOCAL SERVICE	92.02
		40601-2005	TELEPHONE	VOICE OVER TELEPHONE	255.54
	STANDLEY SYSTEMS, LLC	40601-2405	OFFICE SUPPLIES	PRINTER SERVICE AGREEMENT	42.43
		40601-2405	OFFICE SUPPLIES	PRINTER SERVICE AGREEMENT	26.00
	STAPLES ADVANTAGE	40601-2405	OFFICE SUPPLIES	1 CASE COPY PAPER	48.17
	VERIZON	40601-2005	TELEPHONE	FD DATA	320.08
	THE JOHN MAXWELL CO	40601-2615	TRAINING & DEVELOPME	LEADERSHIP TRNG	179.00
				TOTAL:	<u>1,240.85</u>
FIRE PROTECTION	BALLARD'S OF CLINTON INC	40606-2045	VEHICLE REPAIR & MAI	RESCUE OIL CHANGE	98.95
	CLINTON LAUNDRY AND CLEANERS	40606-2111	LAUNDRY RENTALS	MATS MOPS TOWELS	91.31
		40606-2455	SAFETY EQUIPMENT	MED GLOVES	24.00
	ELK SUPPLY CO INC	40606-2470	FACILITIES MAINTENAN	P TRAP IN WALL LEAK	4.87
		40606-2470	FACILITIES MAINTENAN	STATION PICKET	1.87
		40606-2422	PARTS - EQUIPMENT MA	HYDRANT PAINT	11.67
	CHIEF FIRE & SAFETY CO INC	40606-2421	PARTS - VEHICLE MAIN	E3 SWIVEL	130.50
	GALL'S INC	40606-2435	UNIFORM SERVICE	BS WHT SHRT	59.94

FUND: GENERAL FUND

DEPARTMENT	VENDOR NAME	GL ACCOUNT	ACCOUNT DESCRIPTION	DESCRIPTION	AMOUNT
	LITTKE'S STORE	40606-2422	PARTS - EQUIPMENT MA	KUBOTA BLADES	15.00
		40606-2422	PARTS - EQUIPMENT MA	EDGER BLADES	12.00
	LOCKE SUPPLY COMPANY	40606-2470	FACILITIES MAINTENAN	STATION RPR	30.12
		40606-2470	FACILITIES MAINTENAN	STATION	15.11
		40606-2422	PARTS - EQUIPMENT MA	RPRS HYDRANTS	37.71
		40606-2470	FACILITIES MAINTENAN	STATION SUPP	32.66
	WESTERN EQUIPMENT LLC	40606-2422	PARTS - EQUIPMENT MA	PRESSURE WASHER PRTS	23.94
	SANZRO LLC DBA S&D DRUG	40606-2421	PARTS - VEHICLE MAIN	RANGER PARTS	7.18
	SPECIAL-OPS UNIFORMS, INC	40606-2435	UNIFORM SERVICE	GK UNIFORMS	596.41
	WELDON PARTS, INC	40606-2421	PARTS - VEHICLE MAIN	E3 AIR LINE PARTS	22.23
		40606-2421	PARTS - VEHICLE MAIN	CIRCUIT BREAKER ENG3	49.27
		40606-2421	PARTS - VEHICLE MAIN	104 RPR	333.57
	O'REILLY AUTOMOTIVE INC	40606-2421	PARTS - VEHICLE MAIN	TANKER AIR BAG	51.19
		40606-2421	PARTS - VEHICLE MAIN	PARTS ENG3	32.60
		40606-2421	PARTS - VEHICLE MAIN	PUMP SWITCH 104	11.49
		40606-2422	PARTS - EQUIPMENT MA	PRESSURE WASHER O RINGS	8.99
		40606-2420	TIRES, BATTERIES, ET	L11 BATS STATION OIL	686.67
		40606-2421	PARTS - VEHICLE MAIN	E3 PARTS	11.98
	MISCELLANEOUS V MISCELLANEOU	40606-2410	OPERATING SUPPLIES	FD RADIO VC RECORDER SW	480.00
	BACKDRAFT OPCO LLC dba EMERG	40606-2120	CONTRACTUAL SERVICES	ANNUAL SUBS FEE	1,831.60
	H & R AUTO SUPPLY, LLC dba N	40606-2421	PARTS - VEHICLE MAIN	L11 LAMP	15.49
		40606-2421	PARTS - VEHICLE MAIN	E2 PARTS	40.94
		40606-2421	PARTS - VEHICLE MAIN	ANTIFREEZE	11.98
		40606-2422	PARTS - EQUIPMENT MA	RANGER BATT CONNECTOR	17.49
	ALLIED 100, LLC dba AED SUPE	40606-2410	OPERATING SUPPLIES	AED BATS PADS	1,083.60
	ATWOODS	40606-2470	FACILITIES MAINTENAN	SHOP SUPP	71.94
		40606-2470	FACILITIES MAINTENAN	STATION	89.98
		40606-2470	FACILITIES MAINTENAN	RETURNED SPREADER	34.99-
	AMAZON.COM	40606-2435	UNIFORM SERVICE	UNIFORMS DJ DA TC	387.00
		40606-2410	OPERATING SUPPLIES	GRASS MASK FILTERS	399.92
		40606-2410	OPERATING SUPPLIES	STATION SUPP	170.22
		40606-2470	FACILITIES MAINTENAN	SPRAYER	199.99
		40606-2470	FACILITIES MAINTENAN	LAUNDRY DETERGENT	9.98
		40606-2470	FACILITIES MAINTENAN	SCOTTS TURF BUILDER	32.84
		40606-2470	FACILITIES MAINTENAN	STATION SUPP	50.31
		40606-2470	FACILITIES MAINTENAN	LAUNDRY DETERGENT	27.73
	CHASE ENTERPRISES dba CHAPPE	40606-2470	FACILITIES MAINTENAN	PRESSURE WASHER RPRS	773.18
	FIRE SUPPLY INC.	40606-2120	CONTRACTUAL SERVICES	ANNUAL SCBA TESTS	1,600.00
	PATRIOT DIESEL SERVICES LLC	40606-2045	VEHICLE REPAIR & MAI	E3 RPRS	263.95
	TACTICALGEAR.COM	40606-2435	UNIFORM SERVICE	UNIFORMS MS TC DJ	174.60
		40606-2435	UNIFORM SERVICE	REFUNDED SHIPPING COST	8.99-
	NUTRIEN AG SOULTIONS, INC	40606-2470	FACILITIES MAINTENAN	PRAMITOL SPRAY	108.20
			TOTAL:		<u>10,198.19</u>
EMERGENCY MGMT	MISCELLANEOUS V MISCELLANEOU	40607-2615	TRAINING & DEVELOPME	EM MNG MTG LUNCH THE BULL	13.11
			TOTAL:		<u>13.11</u>
INSPECTION	AT&T	41000-2005	TELEPHONE	VOICE OVER TELEPHONE	19.53
	VERIZON	41000-2005	TELEPHONE	EMER MNGMT DATA	80.02
			TOTAL:		<u>99.55</u>
PARKS MAINTENANCE	CLINTON LAUNDRY AND CLEANERS	41108-2435	UNIFORM REPLACEMENT	UNIFORM	22.54
		41108-2435	UNIFORM REPLACEMENT	UNIFORMS	131.21
		41108-2435	UNIFORM REPLACEMENT	UNIFORMS	22.54

FUND: GENERAL FUND

DEPARTMENT	VENDOR NAME	GL ACCOUNT	ACCOUNT DESCRIPTION	DESCRIPTION	AMOUNT
		41108-2435	UNIFORM REPLACEMENT	UNIFORMS	13.25
	ELK SUPPLY CO INC	41108-2470	FACILITIES MAINTENAN	KEY RPLCMNT	17.11
	LINDLEY FARM EQUIP INC	41108-2422	PARTS-EQUIPMENT MAIN	OIL GAUGE	49.40
	LITTKE'S STORE	41108-2410	OPERATING SUPPLIES	BLADES WEEDEATERS	490.00
	WESTERN EQUIPMENT LLC	41108-2422	PARTS-EQUIPMENT MAIN	GRASS DEFLECTOR MOWER RPR	11.09
		41108-2422	PARTS-EQUIPMENT MAIN	AIR FILTER	88.40
		41108-2422	PARTS-EQUIPMENT MAIN	SPINDLE	378.04
		41108-2422	PARTS-EQUIPMENT MAIN	RLL BR FLTRS	865.61
		41108-2422	PARTS-EQUIPMENT MAIN	FILTERS	44.20
		41108-2410	OPERATING SUPPLIES	FLTRS SHLD SHFT	482.13
	AT&T	41108-2005	TELEPHONE	VOICE OVER TELEPHONE	19.53
	O'REILLY AUTOMOTIVE INC	41108-2421	PARTS-VEHICLE MAINT	SPRAY TRK SPRK PLUG	64.60
		41108-2421	PARTS-VEHICLE MAINT	RADTR HOSE INT DR HANDL	25.20
	PROFESSIONAL TURF PRODUCTS L	41108-2422	PARTS-EQUIPMENT MAIN	AIR FILTERS	65.40
	K & S TIRE INC	41108-2420	TIRES, BATTERIES, ET	TRACTOR FLAT RPR	68.33
	STAPLES ADVANTAGE	41108-2405	OFFICE SUPPLIES	TIME CARDS	11.04
	BOBCAT OF OKLAHOMA CITY	41108-2422	PARTS-EQUIPMENT MAIN	ENG OIL DIPSTICK	54.52
	TARGET SPECIALTY PRODUCTS	41108-2440	CHEMICALS	4 JUGS HERBICIDE	160.00
	TEXOMA MEDICAL SERVICES, INC	41108-2420	TIRES, BATTERIES, ET	TURF TIRE	388.80
	ATWOODS	41108-2410	OPERATING SUPPLIES	FNC CLIPS	6.79
		41108-2410	OPERATING SUPPLIES	WTR FR ANT KLLR FLTR	97.91
		41108-2410	OPERATING SUPPLIES	GREASE TOOL	54.89
		41108-2474	LANDSCAPING SUPPLIES	BRWN MULCH	213.85
		41108-2410	OPERATING SUPPLIES	ANT BAIT WSP SPRY	180.65
				TOTAL:	4,027.03
SWIMMING POOL	AT&T	41109-2005	TELEPHONE	VOICE OVER TELEPHONE	19.53
	HAC, INC, DBA HOMELAND, UNIT	41109-2416	CONCESSION SUPPLIES	SODA POP FOR POOL	207.66
	WAL-MART STORE 01-0392	41109-2410	OPERATING SUPPLIES	SUPPLIES FOR THE POOL	109.49
		41109-2410	OPERATING SUPPLIES	MICROWAVE FOR POOL	69.88
	SAM'S CLUB / GECRB	41109-2416	CONCESSION SUPPLIES	CONCESSION SUPPLIES	124.70
	STAPLES ADVANTAGE	41109-2405	OFFICE SUPPLIES	TIME CARDS	11.04
	ATWOODS	41109-2410	OPERATING SUPPLIES	FLY TRAPS FOR POOL	18.47
	AMAZON.COM	41109-2410	OPERATING SUPPLIES	PUMP FOR POOL	53.17
				TOTAL:	613.94
STREETS MAINTENANCE	CLINTON LAUNDRY AND CLEANERS	41208-2435	UNIFORM SERVICE	UNIFORM	19.47
		41208-2435	UNIFORM SERVICE	UNIFORMS	19.47
		41208-2435	UNIFORM SERVICE	UNIFORMS	19.47
		41208-2435	UNIFORM SERVICE	UNIFORMS	19.47
	ELK SUPPLY CO INC	41208-2485	STREET REPAIR & MAIN	STORM DRAIN REPAIRS	55.03
		41208-2485	STREET REPAIR & MAIN	STORM DRAIN REPAIRS	56.26
		41208-2485	STREET REPAIR & MAIN	STORM DRAIN REPAIRS	24.68
		41208-2485	STREET REPAIR & MAIN	MARKING PAINT	10.00
		41208-2485	STREET REPAIR & MAIN	STRM DRN PRP RETURN ITEM	18.75-
	DOLESE BROTHERS CO INC	41208-2485	STREET REPAIR & MAIN	2ND AND FRISCO STREET REPA	175.00
	CKENERGY ELECTRIC COOPERATIV	41208-2076	STREET LIGHTING CHAR	INTERCHANGE LITES	67.72
		41208-2076	STREET LIGHTING CHAR	I40 CHEROKEE LTS	56.82
		41208-2076	STREET LIGHTING CHAR	I40 CHEROKEE LTS	87.63
		41208-2076	STREET LIGHTING CHAR	I40 CHEROKEE LTS	45.59
	WESTERN EQUIPMENT LLC	41208-2422	PARTS-EQUIPMENT MAIN	MOWER TIE ROD	54.83
	OCT EQUIPMENT, INC	41208-2425	FUEL, OIL, ETC.	CASE LOADER ENGINE OIL	130.80
		41208-2422	PARTS-EQUIPMENT MAIN	LOADER ENG TRNSM OIL	212.20
	AT&T	41208-2005	TELEPHONE	VOICE OVER TELEPHONE	19.53

FUND: GENERAL FUND

DEPARTMENT	VENDOR NAME	GL ACCOUNT	ACCOUNT DESCRIPTION	DESCRIPTION	AMOUNT
	WILLIAMS ELECTRIC CO INC	41208-2077	STREET LIGHT REPAIRS	RPR 3 POLE LTS CHEROKEE EX	4,570.34
	WELDON PARTS, INC	41208-2422	PARTS-EQUIPMENT MAIN	LOADER HYDLRC HOSE	97.26
	O'REILLY AUTOMOTIVE INC	41208-2425	FUEL, OIL, ETC.	ANTIFRZ STREET VEH	6.98
		41208-2422	PARTS-EQUIPMENT MAIN	CASE LOADER RPR	6.90
	MISCELLANEOUS V MISCELLANEOU	41208-2615	TRAINING & DEVELOPME	PAYMENT ERROR	6.33
	CELLULAR NETWORK PARTNERSHIP	41208-2005	TELEPHONE	ON CALL CELL PHONE	38.47
				TOTAL:	5,781.50
RECREATION	DOLLAR GENERAL CHARGED SA	41408-2410	OPERATING SUPPLIES	BATTERIES FOR ACME	38.25
	AT&T	41408-2005	TELEPHONE	VOICE OVER TELEPHONE	58.60
	WAL-MART STORE 01-0392	41408-2405	OFFICE SUPPLIES	EQUIPMENT FITNESS AEROBICS	166.62
	AT&T MOBILITY	41408-2020	DATA PROCESSING	INTERNET ARMORY	114.77
	SPARKLIGHT	41408-2020	DATA PROCESSING	CABLE ONE	88.94
	AMERICAN RED CROSS	41408-2615	TRAINING & DEVELOPME	LIFEGUARD CERTIFICATION	38.00
	STAPLES ADVANTAGE	41408-2405	OFFICE SUPPLIES	TIME CARDS	33.12
	AMAZON.COM	41408-2410	OPERATING SUPPLIES	CARD PRINTER INK	180.00
		41408-2410	OPERATING SUPPLIES	WIRELESS MICROPHONE	29.98
		41408-2410	OPERATING SUPPLIES	WRIST BANDS FOR XTREME CLA	85.00
	WHOLESALE FITNESS SUPPLY LLC	41408-2605	DUES, SUBSCRIPTIONS,	MONTHLY PAYMENT	209.90
	DOBSON TECHNOLOGIES TRANSPOR	41408-2020	DATA PROCESSING	INTERNET SERVICE	100.00
				TOTAL:	1,143.18
CEMETERY	CLINTON LAUNDRY AND CLEANERS	41600-2435	UNIFORM SERVICE	UNIFORM	136.67
		41600-2435	UNIFORM SERVICE	UNIFORMS	18.71
		41600-2435	UNIFORM SERVICE	UNIFORMS	18.71
		41600-2435	UNIFORM SERVICE	UNIFORMS	18.71
	AT&T	41600-2005	TELEPHONE	VOICE OVER TELEPHONE	19.53
				TOTAL:	212.33
FACILITIES MAINTENANCE	CLINTON LAUNDRY AND CLEANERS	41700-2435	UNIFORM SERVICE	UNIFORMS	9.29
		41700-2435	UNIFORM SERVICE	UNIFORMS	117.96
		41700-2435	UNIFORM SERVICE	UNIFORMS	9.29
	ELK SUPPLY CO INC	41700-2130	FACILITIES REPAIR	NUTS BOLTS SCRWS LIBRARY	1.77
	CKENERGY ELECTRIC COOPERATIV	41700-2075	ELECTRIC CHARGES	BILLBOARD SIGN	35.70
	AT&T	41700-2005	TELEPHONE	BUSINESS LOCAL SERVICE	76.55
		41700-2005	TELEPHONE	BUSINESS LOCAL SERVICE	82.92
		41700-2005	TELEPHONE	EASTSIDE ALARM	194.42
		41700-2005	TELEPHONE	EASTSIDE ALARM	191.55
		41700-2005	TELEPHONE	VOICE OVER TELEPHONE	58.60
		41700-2020	DATA PROCESSING	VOICE OVER TELEPHONE	19.53
	TERMINIX INTERNATIONAL	41700-2120	CONTRACTUAL SERVICES	PEST CONTROL	5,500.00
	MISCELLANEOUS V MISCELLANEOU	41700-2020	DATA PROCESSING	CLINTONOKLAORG DOMAIN	79.98
	MISCELLANEOU	41700-2020	DATA PROCESSING	ONLINE FORMS TRIAL	8.33
	MISCELLANEOU	41700-2020	DATA PROCESSING	CLINTONOKGOV REGISTRATION	400.00
	SPARKLIGHT	41700-2020	DATA PROCESSING	CABLE ONE	132.28
		41700-2020	DATA PROCESSING	CABLE ONE	280.00
	AMAZON.COM	41700-2020	DATA PROCESSING	DATA COUPLING ETHER	67.77
		41700-2020	DATA PROCESSING	FIREWALL MOUNT	274.00
		41700-2130	FACILITIES REPAIR	SERVER HARD DRIVE REPL	250.92
		41700-2020	DATA PROCESSING	UPS BATTERY REPL	273.42
		41700-2020	DATA PROCESSING	FIREWALL REPL	349.00
		41700-2130	FACILITIES REPAIR	LAPTOP POWER ADAPTER	18.98
		41700-2020	DATA PROCESSING	MGR LAPTOP CHARGER AND HAR	60.67
		41700-2020	DATA PROCESSING	LAPTOP HARDDRIVE REPL ONHA	46.68

FUND: GENERAL FUND

DEPARTMENT	VENDOR NAME	GL ACCOUNT	ACCOUNT DESCRIPTION	DESCRIPTION	AMOUNT
		41700-2020	DATA PROCESSING	LAPTOP PWR SUPPLY	38.88
		41700-2020	DATA PROCESSING	IT DIR UPS REPL	209.95
	INTERLINEBRANDS, INC. dba SU	41700-2465	JANITORIAL SUPPLIES	PAPER GOODS CLEANING SUPPL	403.56
		41700-2410	OPERATING SUPPLIES	3 CASES KLEENEX TOWELS	213.00
	DOBSON TECHNOLOGIES TRANSPOR	41700-2020	DATA PROCESSING	INTERNET SERVICE	869.84
				TOTAL:	<u>10,274.84</u>

FUND: CAPITAL IMPROVEMNT

DEPARTMENT	VENDOR NAME	GL ACCOUNT	ACCOUNT DESCRIPTION	DESCRIPTION	AMOUNT
FIRE PROTECTION	TOTAL RADIO INC	40606-3025	VEHICLES	CONV TO US DOLLARS	0.57
		40606-3025	VEHICLES	MOUNT ANT COIL BP103	57.43
				TOTAL:	<u>58.00</u>
PARKS MAINTENANCE	DOLESE BROTHERS CO INC	41108-3035	IMPROVEMENTS OTHER T	CNCRT WALL HS TENNIS COURT	1,800.00
				TOTAL:	<u>1,800.00</u>

FUND: HOUSING/HOPE VI FUND

DEPARTMENT	VENDOR NAME	GL ACCOUNT	ACCOUNT DESCRIPTION	DESCRIPTION	AMOUNT
HOUSING-HOPE VI MAIN S	ELK SUPPLY CO INC	44900-2130	FACILITIES REPAIR	CEILING RPR HOPE APTS	67.97
		44900-2130	FACILITIES REPAIR	CEILING RPR HOPE APTS	13.66
	AT&T	44900-2005	TELEPHONE	HOPE LOCAL SERVICE	167.65
		44900-2005	TELEPHONE	HOPE ALARM LOCAL SERVICE	165.17
		44900-2005	TELEPHONE	HOPE LOCAL SERVICE	165.17
		44900-2005	TELEPHONE	HOPE ALARM LOCAL SERVICE	167.65
	T.H. ROGERS LUMBER CO.	44900-2130	FACILITIES REPAIR	CEILING RPR HOPE APTS	4.99
				TOTAL:	<u>752.26</u>

FUND: PUBLIC WORKS AUTHORI

DEPARTMENT	VENDOR NAME	GL ACCOUNT	ACCOUNT DESCRIPTION	DESCRIPTION	AMOUNT	
WATER ADMINISTRATION	AT&T	40701-2005	TELEPHONE	VOICE OVER TELEPHONE	39.07	
	STANDLEY SYSTEMS, LLC	40701-2405	OFFICE SUPPLIES	PRINTER SERVICE AGREEMENT	77.12	
	STAPLES ADVANTAGE	40701-2405	OFFICE SUPPLIES	TIME CARDS	11.04	
	VERIZON	40701-2005	TELEPHONE	PUBLIC WORKS DIR DATA	40.01	
				TOTAL:	<u>167.24</u>	
WATER MAINTENANCE	CLINTON LAUNDRY AND CLEANERS	40708-2435	UNIFORM SERVICE	UNIFORM	68.91	
		40708-2435	UNIFORM SERVICE	UNIFORMS	68.91	
	CKENERGY ELECTRIC COOPERATIV	40708-2075	ELECTRIC CHARGES	DIXON WELL	91.35	
		40708-2075	ELECTRIC CHARGES	CANYONS WEST	230.46	
		40708-2075	ELECTRIC CHARGES	N WELL	37.25	
	LOCKE SUPPLY COMPANY	40708-2130	FACILITIES REPAIR	WTR SHOP TOILET RPR	15.77	
		40708-2410	OPERATING SUPPLIES	WTR LINE RPR PARTS	33.62	
		40708-2410	OPERATING SUPPLIES	WTR LINE RPR PART RTN	18.15-	
	OCT EQUIPMENT, INC	40708-2422	PARTS-EQUIPMENT MAIN	FUEL FILTER	37.50	
		40708-2422	PARTS-EQUIPMENT MAIN	BACK HOE FUEL FILT CRTRDG	27.00	
		40708-2422	PARTS-EQUIPMENT MAIN	BACK HOE SENSOR	71.50	
	PIONEER SUPPLY CO, LLC	40708-2410	OPERATING SUPPLIES	VO TRAFFIC RPR KIT	549.16	
		40708-2410	OPERATING SUPPLIES	WTR LINE RPR PARTS	289.20	
		40708-2410	OPERATING SUPPLIES	PLSTC METER BOXES	727.20	
		40708-2410	OPERATING SUPPLIES	BALL VLV W LOCK	762.00	
		40708-3015	WATER METERS	WATER METERS	3,567.00	
		40708-2410	OPERATING SUPPLIES	BALL VLV RESETTER	782.50	
	AT&T	40708-2005	TELEPHONE	VOICE OVER TELEPHONE	19.53	
	T.H. ROGERS LUMBER CO.	40708-2410	OPERATING SUPPLIES	RAKE SHOVL	57.98	
		40708-2410	OPERATING SUPPLIES	PVC PIPE	6.80	
	O'REILLY AUTOMOTIVE INC	40708-2425	FUEL, OIL, ETC.	OIL FILTER	25.12	
		40708-2421	PARTS-VEHICLE MAINT	SHIFT TUBE	42.97	
		40708-2422	PARTS-EQUIPMENT MAIN	AIR FILTER	27.65	
	MISCELLANEOUS V MISCELLANEOU	40708-2005	TELEPHONE	SCADA ALARMS TEXT	20.00	
		MISCELLANEOU 40708-2005	TELEPHONE	SCADA ALARM TEXT	20.00	
		MISCELLANEOU 40708-2005	TELEPHONE	SCADA ALARM TEXT	20.00	
		MISCELLANEOU 40708-2005	TELEPHONE	SCADA ALARM TEXT	20.00	
	K & S TIRE INC	40708-2420	TIRES, BATTERIES, ET	FLAT REPAIR	15.00	
	LAMPTON WELDING SUPPLY CO IN	40708-2410	OPERATING SUPPLIES	CYLNR YEARLY LEASE	74.95	
	STAPLES ADVANTAGE	40708-2405	OFFICE SUPPLIES	TIME CARDS	11.04	
	H & R AUTO SUPPLY, LLC dba N	40708-2422	PARTS-EQUIPMENT MAIN	FUNNEL OIL PLUGS	86.84	
	ATWOODS	40708-2470	FACILITIES MAINTENAN	AC UNIT EXT CORD	284.98	
		40708-2410	OPERATING SUPPLIES	CLAMPS	11.99	
	AMAZON.COM	40708-2130	FACILITIES REPAIR	SCADA TOWER REPAIR	134.96	
		40708-2046	EQUIP REPAIR & MAINT	SCADA TOWER REPAIR	1,012.89	
	VERIZON	40708-2005	TELEPHONE	PUBLIC WORKS MAINT DATA	40.01	
	CORE & MAIN LP	40708-2410	OPERATING SUPPLIES	GASKETS	21.44	
				TOTAL:	<u>9,295.33</u>	
	WATER TREATMENT	SPARKLIGHT	40710-2005	TELEPHONE	CABLE ONE	400.00
		VERIZON	40710-2410	OPERATING SUPPLIES	LAKE SCADA FAILOVER	10.02
					TOTAL:	<u>410.02</u>
	RO WTR TREATMENT PLANT	CKENERGY ELECTRIC COOPERATIV	40715-2075	ELECTRIC CHARGES	BOOSTER PUMP JEHOVAH	153.74
		40715-2075	ELECTRIC CHARGES	RADIO TRANSMITTER	36.70	
MISCELLANEOUS V MISCELLANEOU		40715-2130	FACILITIES REPAIR	RO PLANT CONNECTIVITY SCAD	439.81	
				TOTAL:	<u>630.25</u>	

FUND: PUBLIC WORKS AUTHORI

DEPARTMENT	VENDOR NAME	GL ACCOUNT	ACCOUNT DESCRIPTION	DESCRIPTION	AMOUNT
WASTEWATER MAINTENANCE	CLINTON LAUNDRY AND CLEANERS	40808-2435	UNIFORM SERVICE	UNIFORMS	68.91
		40808-2435	UNIFORM SERVICE	UNIFORMS	68.91
	ELK SUPPLY CO INC	40808-2422	PARTS-EQUIPMENT MAIN	PVC TRCTR RPR	15.40
	CELLULAR NETWORK PARTNERSHIP	40808-2005	TELEPHONE	ON CALL CELL PHONE	38.47
				TOTAL:	<u>191.69</u>

FUND: SOLID WASTE AUTHORIT

DEPARTMENT	VENDOR NAME	GL ACCOUNT	ACCOUNT DESCRIPTION	DESCRIPTION	AMOUNT
SOLID WASTE COLLECTION	CLINTON LAUNDRY AND CLEANERS	40912-2435	UNIFORM SERVICE	UNIFORM	75.82
		40912-2435	UNIFORM SERVICE	UNIFORMS	75.82
		40912-2435	UNIFORM SERVICE	UNIFORMS	75.82
		40912-2435	UNIFORM SERVICE	UNIFORMS	75.82
WESTERN EQUIPMENT LLC	WELDON PARTS, INC	40912-2410	OPERATING SUPPLIES	SHOP VEH RPR SUPPLIES	335.00
		40912-2421	PARTS-VEHICLE MAINT	CABLE CLAMP UNIT 16	637.00
		40912-2421	PARTS-VEHICLE MAINT	CABLE UNIT 24	272.43
		40912-2421	PARTS-VEHICLE MAINT	RADIATOR UNIT 22	855.05
O'REILLY AUTOMOTIVE INC		40912-2410	OPERATING SUPPLIES	GLOVES	131.88
		40912-2420	TIRES, BATTERIES, ET	BATTERY REPLC	103.40
		40912-2420	TIRES, BATTERIES, ET	BATTERY REPLCMNT	244.24
		40912-2426	PARTS - DUMPSTER REP	COMP OXYGEN	30.40
LAMPTON WELDING SUPPLY CO IN		40912-2426	PARTS - DUMPSTER REP	DRIVE ROLL CORE WIRE	152.77
		40912-2005	TELEPHONE	ON CALL CELL PHONE	36.22
STAPLES ADVANTAGE		40912-2405	OFFICE SUPPLIES	TIME CARDS	11.04
		40912-2410	OPERATING SUPPLIES	BOTTLED WATER	23.88
ATWOODS		40912-2410	OPERATING SUPPLIES	RPR DUMP GATE	12.84
		40912-2421	PARTS-VEHICLE MAINT	VEH RPR UNIT 21	8.57
		40912-2426	PARTS - DUMPSTER REP	DRILL BIT DUMPSTR RPR	53.38
		40912-2405	OFFICE SUPPLIES	OFFICE SUP SANT DUMP SITE	16.57
DANNY L. WATKINS dba CLINTON		40912-2045	VEHICLE REPAIR & MAI	AC REPAIRS UNIT 16	569.00
OMAHA STANDARD, LLC, NJ		40912-2421	PARTS-VEHICLE MAINT	RPR UNIT 16	32.83
				TOTAL:	<u>3,829.78</u>

FUND: CLINTON AIRPORT AUTH

DEPARTMENT	VENDOR NAME	GL ACCOUNT	ACCOUNT DESCRIPTION	DESCRIPTION	AMOUNT
AIRPORT	WESTERN EQUIPMENT LLC	42700-2422	PARTS-EQUIPMENT MAIN	NUT FOR MOWER TIRE	3.23
	AT&T	42700-2005	TELEPHONE	BUSINESS LOCAL SERVICE	76.55
		42700-2005	TELEPHONE	LOCAL PHONE SERVICE	165.79
		42700-2005	TELEPHONE	BUSINESS LOCAL SERVICE	82.92
		42700-2005	TELEPHONE	VOICE OVER TELEPHONE	19.55
	SANZRO LLC DBA S&D DRUG	42700-2405	OFFICE SUPPLIES	PRINTER PAPER	34.95
	DOMINO EQUIPMENT CO LLC	42700-2410	OPERATING SUPPLIES	MEASURE STICKS FUEL TANKS	57.28
	O'REILLY AUTOMOTIVE INC	42700-2422	PARTS-EQUIPMENT MAIN	BATTERY FOR BAD BOY MOWER	28.64
	DOMINO FOOD & FUEL INC	42700-2425	FUEL, OIL, ETC	FUEL PICKUP USED WRONG CAR	23.05
	DISH NETWORK	42700-2120	CONTRACTUAL SERVICES	DISH NETWORK CRA	54.55
	K & S TIRE INC	42700-2046	EQUIPMENT REPAIR & M	TIRE AND REPAIR FOR MOWER	263.20
	ATWOODS	42700-2422	PARTS-EQUIPMENT MAIN	TIRE SEALANT AND WASP SPRA	35.94
	NUTRIEN AG SOULTIONS, INC	42700-2475	LAND MAINTENANCE	WEED SPRAY	162.20
				TOTAL:	<u>1,007.85</u>

FUND: RECREATION TRUST AUT

DEPARTMENT	VENDOR NAME	GL ACCOUNT	ACCOUNT DESCRIPTION	DESCRIPTION	AMOUNT	
GOLF COURSE ADMINISTRA	ARTIC AIR REFRIG. INC.	41301-2055	MAINTENANCE/OTHER	SCHEDULE MAINTENANCE	365.00	
	CLINTON LAUNDRY AND CLEANERS	41301-2465	JANITORIAL SUPPLIES	BAR MOPS	37.36	
		41301-2465	JANITORIAL SUPPLIES	BAR MOPS	37.36	
	AT&T	41301-2005	TELEPHONE	BUSINESS LOCAL SERVICE	76.55	
		41301-2005	TELEPHONE	BUSINESS LOCAL SERVICE	82.92	
	SUNSHINE FARM & NURSERY	41301-2460	MISCELLANEOUS	MULCH	50.00	
	EASY PICKER GOLF PRODUCTS	41301-2410	OPERATING SUPPLIES	BEARINGS	84.96	
	DISH NETWORK	41301-2410	OPERATING SUPPLIES	DISH NETWORK GC	154.04	
				TOTAL:	<u>888.19</u>	
	GOLF COURSE MAINTENANC	CLINTON LAUNDRY AND CLEANERS	41308-2435	UNIFORM SERVICE	UNIFORM	9.19
			41308-2435	UNIFORM SERVICE	UNIFORMS	9.19
		41308-2435	UNIFORM SERVICE	UNIFORMS	9.19	
		41308-2435	UNIFORM SERVICE	UNIFORMS	127.15	
ELK SUPPLY CO INC		41308-2410	OPERATING SUPPLIES	PVC PLUG	4.86	
JACKS GOLF CARS II		41308-2045	VEHICLE REPAIR & MAI	SERVICE ON EQUIPMENT	115.00	
LOCKE SUPPLY COMPANY		41308-2410	OPERATING SUPPLIES	RED AND TAN WIRE	12.06	
		41308-2410	OPERATING SUPPLIES	BLUE CEMENT BLUE MOSTER TA	16.74	
WESTERN EQUIPMENT LLC		41308-2045	VEHICLE REPAIR & MAI	OIL CHANGE	280.84	
		41308-2422	PARTS - EQUIPMENT MA	SPACER QUICK LOCK GUARD	48.07	
R & R PRODUCTS, INC		41308-2410	OPERATING SUPPLIES	GOLF TURF MARKING PAINT	75.47	
2-D TRAILER SALES		41308-2410	OPERATING SUPPLIES	TUBING SOCKET MOUNT HOOK	31.10	
HD SUPPLY FACILITIES MAINTEN		41308-2421	PARTS - VEHICLE MAIN	TUBING AIR FILTER GAUGE VA	99.76	
ATWOODS		41308-2442	GRAVEL/TOPSOIL/FILL	ROCK WHITE CRYSTAL	179.60	
		41308-2410	OPERATING SUPPLIES	TRIMMER LINE	17.99	
		41308-2410	OPERATING SUPPLIES	BAR & CHAIN OIL	6.99	
		41308-2410	OPERATING SUPPLIES	LOPPER ANVIL FOR PRUNING	26.99	
P.B. HOIDALE CO., INC.		41308-2410	OPERATING SUPPLIES	SUPER SWIVEL VITON	89.79	
				TOTAL:	<u>1,159.98</u>	

FUND: CLINTON INDUSTRIAL A

DEPARTMENT	VENDOR NAME	GL ACCOUNT	ACCOUNT DESCRIPTION	DESCRIPTION	AMOUNT
CONF CTR OPERATION	CLINTON DAILY NEWS	41508-2016	ADVERTISING	BAR S APPR AND PATRIOT ADS	346.82
	AT&T	41508-2005	TELEPHONE	VOICE OVER TELEPHONE	63.89
	UNITED SUPERMARKET	41508-2470	FACILITIES MAINTENAN	FOIL FOR OVER	7.99
	WRIGHT BROADCASTING	41508-2016	ADVERTISING	RADIO ADS	499.00
	KECO	41508-2016	ADVERTISING	RADIO ADS	785.00
	EVENT PRO SOFTWARE	41508-2120	CONTRACTUAL SERVICES	SOFTWARE UPDATE	953.43
	SPARKLIGHT	41508-2020	DATA PROCESSING	CABLE ONE	400.00
	MULTIVIEW, INC. USA	41508-2016	ADVERTISING	LISTING FOR GUIDE BOOK	695.00
	OSWALT EQUIPMENT COMPANY	41508-2465	JANITORIAL SUPPLIES	DISH WASHING CASES	47.74
	SIMPLE SOLUTIONS , LLC	41508-2120	CONTRACTUAL SERVICES	LAWN MOWING	700.00
	iHEART MEDIA ENTERTAINMENT,	41508-2016	ADVERTISING	RADIO ADS	1,760.00
	PROSTAR OKLAHOMA INC. dba PA	41508-2410	OPERATING SUPPLIES	COFFEE AND TEA	47.16
				TOTAL:	<u>6,306.03</u>

```

===== FUND TOTALS =====
100 GENERAL FUND                43,572.32
430 CAPITAL IMPROVEMNT          1,858.00
520 HOUSING/HOPE VI FUND         752.26
700 PUBLIC WORKS AUTHORITY      10,694.53
710 SOLID WASTE AUTHORITY        3,829.78
720 CLINTON AIRPORT AUTHORITY    1,007.85
730 RECREATION TRUST AUTHOR.     2,048.17
740 CLINTON INDUSTRIAL AUTH.     6,306.03
-----
GRAND TOTAL:                    70,068.94
-----

```

TOTAL PAGES: 14

SELECTION CRITERIA

SELECTION OPTIONS

VENDOR SET: 01-CITY OF CLINTON
VENDOR: All
CLASSIFICATION: All
BANK CODE: Include: PCARD
ITEM DATE: 0/00/0000 THRU 99/99/9999
ITEM AMOUNT: 99,999,999.00CR THRU 99,999,999.00
GL POST DATE: 7/01/2020 THRU 7/31/2020
CHECK DATE: 0/00/0000 THRU 99/99/9999

PAYROLL SELECTION

PAYROLL EXPENSES: NO
EXPENSE TYPE: N/A
CHECK DATE: 0/00/0000 THRU 99/99/9999

PRINT OPTIONS

PRINT DATE: None
SEQUENCE: By Department
DESCRIPTION: Distribution
GL ACCTS: YES
REPORT TITLE: C O U N C I L R E P O R T
SIGNATURE LINES: 0

PACKET OPTIONS

INCLUDE REFUNDS: NO
INCLUDE OPEN ITEM:NO

PUBLIC NOTICE OF MEETING

REGULAR MEETING OF CLINTON HOSPITAL AUTHORITY

TUESDAY, SEPTEMBER 1, 2020

CLINTON CITY HALL

5:30 P.M.

AGENDA

- 1. Call to Order**
- 2. Opening Prayer/Pledge: Pat Peters, Church of Christ**
- 3. Consent Agenda**
 - A. Consider approval of minutes of August 4, 2020**
 - B. Consider Claims**
- 4. Action Items:**
- 5. Trustee Report**
- 6. City Manager's Report**
- 7. Adjournment**

Filed this _____ day of _____, 2020

Posted on the bulletin board in the lobby of the Clinton City Hall on

_____, 2020, _____ A.M./P.M.

Debra Blanchard, Acting City Clerk

**MINUTES OF HOSPITAL AUTHORITY MEETING
AUGUST 4, 2020**

Minutes of the regular meeting of the Chairman and Trustees of the Clinton Hospital Authority, City of Clinton, Oklahoma, Custer County, held in the City Council Room, City Hall on Tuesday, August 4, 2020, at 5:30 p.m. A notice of this meeting with agenda was posted on the bulletin board in the lobby of Clinton City Hall on Friday, July 31, 2020.

Chairman David Berrong called the meeting to order with the following present;

CHAIRMAN: David Berrong

TRUSTEES: Patch McComas, Ernie Dowdell, Bobby Stewart, Chris Jones

ACTING CITY MANAGER: Gene McCullough

CITY TREASURER: Debra Blanchard

CITY ATTORNEY: Ryan Meacham

DEPUTY TREASURER: Shona Stermer

NEWS MEDIA: Rod Serfoss and Mike Smith

OTHERS: Paul Rinkel, Donnie Phipps, Gary Kluckner, Pat Peters, Rhonda Williams

Pat Peters opened the meeting with prayer and Trustee Bobby Stewart led the Pledge of Allegiance.

AGENDA ITEM NO. 3: CONSENT AGENDA

- A. Minutes of Regular Meeting of July 7, 2020
- B. Consider claims

Moved by Trustee Jones and seconded by Trustee Dowdell, that Consent Agenda Item No. 3 (a-b) be approved.

Chairman put the motion to a roll call vote:

Aye: Jones, Dowdell, Stewart, McComas, Berrong

Nay: None

Chairman declared the motion carried.

AGENDA ITEM NO. 4 ACTION ITEMS

None

AGENDA ITEM NO. 5 TRUSTEES REPORT

None

AGENDA ITEM NO. 6: CITY MANAGER'S REPORT

None

AGENDA ITEM NO. 7: AUDIENCE PARTICIPATION

None

AGENDA ITEM NO. 8: ADJOURNMENT

Moved by Trustee Dowdell and seconded by Trustee Jones to adjourn the meeting.

Chairman put the motion to a roll call vote:

Aye: Dowdell, Jones, Stewart, McComas, Berrong

Nay: None

Chairman declared the meeting adjourned at 5:31 p.m.

PUBLIC NOTICE OF MEETING

REGULAR MEETING OF CLINTON INDUSTRIAL AUTHORITY

TUESDAY, SEPTEMBER 1, 2020

CLINTON CITY HALL

5:30 P.M.

AGENDA

- 1. Call To Order**
- 2. Opening Prayer/Pledge** **Pat Peters, Church of Christ**
- 3. Consent Agenda**
 - A. Consider approval of minutes of August 4, 2020**
 - B. Consider claims**
- 4. Action Items:**
 - A. Consider and take action on request for tourism funds.**
- 5. Trustee Report**
- 6. City Manager's Report**
- 7. Adjournment**

Filed this _____ day of _____, 2020

Posted on the bulletin board in the lobby of the Clinton City Hall on
_____, 2020 _____ A.M./P.M.

Debra Blanchard, Acting City Clerk

**MINUTES OF INDUSTRIAL AUTHORITY MEETING
AUGUST 4, 2020**

Minutes of the regular meeting of the Chairman and Trustees of the Clinton Industrial Authority City of Clinton, Oklahoma, Custer County, held in the City Council Room, City Hall on Tuesday, August 4, 2020, at 5:30 p.m. A notice of this meeting with agenda was posted on the bulletin board in the lobby of Clinton City Hall on Friday, July 31, 2020.

Chairman David Berrong called the meeting to order with the following present;

CHAIRMAN: David Berrong

TRUSTEES: Patch McComas, Ernie Dowdell, Bobby Stewart, Chris Jones

ACTING CITY MANAGER: Gene McCullough

CITY TREASURER: Debra Blanchard

CITY ATTORNEY: Ryan Meacham

DEPUTY TREASURER: Shona Stermer

NEWS MEDIA: Rod Serfoss and Mike Smith

OTHERS: Paul Rinkel, Donnie Phipps, Gary Kluckner, Pat Peters, Rhonda Williams

Pat Peters opened the meeting with prayer and Trustee Bobby Stewart led the Pledge of Allegiance.

AGENDA ITEM NO. 3: CONSENT AGENDA

- A. Minutes of Regular Meeting of July 21, 2020
- B. Consider claims

Moved by Trustee Jones and seconded by Trustee Dowdell, that Consent Agenda Item No. 3 (a-b) be approved.

Chairman put the motion to a roll call vote:

Aye: Jones, Dowdell, Stewart, McComas, Berrong

Nay: None

Chairman declared the motion carried.

AGENDA ITEM NO. 4 ACTION ITEMS

None

AGENDA ITEM NO. 5 TRUSTEES REPORT

None

AGENDA ITEM NO. 6: CITY MANAGER'S REPORT

None

AGENDA ITEM NO. 7: AUDIENCE PARTICIPATION

None

AGENDA ITEM NO. 8: ADJOURNMENT

Moved by Trustee Dowdell and seconded by Trustee Jones to adjourn the meeting.

Chairman put the motion to a roll call vote:

Aye: Dowdell, Jones, Stewart, McComas, Berrong

Nay: None

Chairman declared the meeting adjourned at 5:34 p.m.



Agenda Commentary

Item Title/ Subject: Request from Tourism Funds for Clinton Men’s Golf Association

Staff Source: Gene McCullough, Acting City Manager

Date: September 1, 2020

History/Background Information: The Tourism Fund has been established to provide funds for local organizations and events that promote Clinton and bring additional commerce to our town.

Subject Summary: The Clinton Men’s Golf Association is hosting the Clinton Labor Day Golf Tournament at the Riverside Golf Course. They have requested \$5,000.00 “to offset cost of putting the tournament on, green fees, carts, range balls, food & drink, etc.” Anticipated economic benefit to the City of Clinton is estimated at \$100,000.00.

Recommendation: The Clinton Chamber of Commerce Executive Board has recommended approval of the request for funds.

Price/Cost: \$5,000.00



Meeting/Event Grant Application

Requests Must be Submitted Prior to the 1st Tuesday of Each Month to be included in the Chamber of Commerce Executive Board Agenda.
Applications should be mailed to: The Clinton Chamber of Commerce 101 S. 4th St. Clinton, OK 73601.

Organization Applicant Information

Organization/Agency Name: Clinton Men's Golf Association		Date: 8/28/20
Mailing Address:		Phone: (580) 331-7706
City: Clinton	State: OK	ZIP Code: 73601
Year Founded/Established:	Non-Profit: <input checked="" type="radio"/> Yes <input type="radio"/> No (Please circle)	Website:
Type of Organization/Agency (brief description of activities and primary purpose): TO PROMOTE		

Event/Emergency Contact Information

Event Contact Person: MATT EVANS		Title: Pres
Address: 10329 N. 2265 RD		Phone: (580) 331-7706
City: Clinton	State: OK	Zip: 73601
Email Address: matt.evans@sportsschassis.com		2 nd Phone: (580) 214-0581

Meeting/Event Information

Name of Meeting/Event: Clinton Labor Day Golf Tournament			
Date Event Begins	9-4-20	Date Event Ends	9-6-20
Full Description of proposed Fund usage for Meeting/Event (Be specific): TO OFFSET COST OF PUTTING THE TOURNAMENT ON, GREEN FEES, CARTS, RANGE BALLS, FOOD & DRINK ETC.			

Date of Last Meeting/Event	8/30/19	Number/Years Previously Received Funds	0	Meeting/Event Funding Amount Requested:	\$ 5000
----------------------------	----------------	--	----------	---	----------------



Meeting/Event Grant Application (Continued)

Organization/Agency Name:	Date:
---------------------------	-------

Economic Impact

Anticipated Economic Benefit or Impact to the City of Clinton: **\$100,000**

Expected Visitor Attendance to Clinton:	250	Local Visitors (within 75 miles)	100	Area Visitors (outside 75 miles)	150	Out of State Visitors	50
---	------------	----------------------------------	------------	----------------------------------	------------	-----------------------	-----------

Total Expected Number of Hotel/Motel Room Nights Required (# nights x # rooms): **150** Host Hotel/Motel: **All**

Overflow Hotels/Motels:

Anticipated Meeting/Event Facilities Required: **Riverside Golf Course**

Dispersal Information

Name and Address to Appear on Check: **CMGA**

Name: **CLINTON MEN'S GOLF ASSOCIATION**

Address: **10329 N. 2265 Rd**

City: **Clinton** State: **OK.** ZIP Code: **73601**

Terms

We acknowledge the Organization information included in this application is true and accurate with no facts having been in any way misrepresented. Should an approved event be CANCELED after the funds have been disbursed, then we, the Organization, agree to repay all funds received within 30 days of the scheduled event or date of cancellation.

Authorized Applicant Signature: Applicant Title: **Pres.**

Printed Name: **MATT EVANS** Application Date: **8/28/20**

Before submitting this request, please ensure all pages have been completed in their entirety and proper signatures are included. If a question is not answered, please state why it is not answered.

Funding Process

The Clinton Chamber of Commerce Executive Board will review all applications during the Executive Session scheduled on the 2nd Wednesday of each month. Once reviewed, recommendations will be presented to the City of Clinton City Council during 3rd Tuesday regularly scheduled meetings. A representative from the organization requesting funds may be present at the Clinton Chamber of Commerce Executive Board meeting and the Clinton City Council meeting to address any questions or concerns.

Clinton Chamber of Commerce Executive Board Funding Recommendation

Grant Amount Recommended to the Clinton City Council for Final Approval: \$ **5000** Date: **8/28/2020**

Signature of Clinton Chamber of Commerce Board Chair or Acting Chair: Printed Name: **Julie Caldwell**

For Executive Board

PUBLIC NOTICE OF MEETING
REGULAR MEETING OF CLINTON PUBLIC WORKS AUTHORITY

TUESDAY, SEPTEMBER 1, 2020

CLINTON CITY HALL

5:30 P.M.

AGENDA

- 1. Call to Order**
- 2. Opening Prayer/Pledge** **Pat Peters, Church of Christ**
- 3. Consent Agenda**
 - A. Consider approval of minutes of August 4, 2020**
 - B. Consider claims**
- 4. Action Items:**
- 5. Trustee Report**
- 6. City Manager's Report**
- 7. Adjournment**

Filed this _____ day of _____, 2020

Posted on the bulletin board in the lobby of the Clinton City Hall on

_____, 2020, _____ A.M./P.M.

Debra Blanchard, Acting City Clerk

**MINUTES OF CLINTON PUBLIC WORKS AUTHORITY MEETING
AUGUST 4, 2020**

Minutes of the regular meeting of the Chairman and Trustees of the Clinton Public Works Authority of Clinton, Oklahoma, Custer County, held in the City Council Room, City Hall on Tuesday, August 4, 2020, at 5:30 p.m. A notice of this meeting with agenda was posted on the bulletin board in the lobby of Clinton City Hall on July 31, 2020.

Chairman David Berrong called the meeting to order with the following present:

CHAIRMAN: David Berrong

TRUSTEES: Patch McComas, Ernie Dowdell, Bobby Stewart, Chris Jones

ACTING CITY MANAGER: Gene McCullough

CITY TREASURER: Debra Blanchard

CITY ATTORNEY: Ryan Meacham

DEPUTY TREASURER: Shona Stermer

NEWS MEDIA: Rod Serfoss and Mike Smith

OTHERS: Paul Rinkel, Donnie Phipps, Gary Kluckner, Pat Peters, Rhonda Williams

Pat Peters opened the meeting with prayer and Trustee Bobby Stewart led the Pledge of Allegiance.

AGENDA ITEM NO. 3: CONSENT AGENDA

- A. Minutes of Regular Meeting of July 21, 2020
- B. Consider claims

Motion was made by Trustee Dowdell and seconded by Trustee McComas, that Consent Agenda Item No. 3 (a-b) be approved.

Chairman put the motion to a roll call vote:

Aye: Dowdell, McComas, Jones, Stewart, Berrong

Nay: None

Chairman declared the motion carried.

AGENDA ITEM NO. 4 ACTION ITEM

4A. CONSIDER AND TAKE ACTION ON REQUEST TO PURCHASE A COMPACT EXCAVATOR FOR WATER MAINTENANCE DEPARTMENT.

Acting City Manager, Gene McCullough, stated that this compact excavator is a budgeted item in this fiscal year. Water Maintenance Supervisor, Gary Kluckner, stated that the Water Maintenance Department would use a compact excavator on a daily basis. Also, a good compact excavator would last for about 10 years. Kluckner stated they received state bid pricing.

Motion was made by Trustee Stewart and seconded Trustee Jones that the purchase of a compact excavator for the Water Maintenance Department be approved.

Chairman put the motion to a roll call vote:

Aye: Stewart, Jones, Dowdell, McComas, Berrong
Nay: None

Chairman declared the motion carried.

4B. CONSIDER AND TAKE ACTION ON REQUEST TO PURCHASE A BACKHOE FOR WATER MAINTENANCE DEPARTMENT.

Acting City Manager, Gene McCullough, stated this is also a budgeted item in this fiscal year. Solid Waste Supervisor, Donnie Phipps, stated currently the Water Maintenance Department borrows a compact backhoe from the Street's Department and the Solid Waste Department to move roll offs. At this time, the backhoe uses 10 to 15 gallons a day of hydraulic fluid, which costs between \$600 and \$700 a month in hydraulic fluid.

McCullough also stated that the City received state bid pricing.

Motion was made by Trustee Stewart and seconded Trustee Jones that the purchase of a backhoe for the Water Maintenance Department be approved.

Chairman put the motion to a roll call vote:

Aye: Stewart, Jones, Dowdell, McComas, Berrong
Nay: None

Chairman declared the motion carried.

AGENDA ITEM NO. 5 TRUSTEE REPORT

None

AGENDA ITEM NO. 6: CITY MANAGER'S REPORT

Acting City Manager, Gene McCullough, stated that the Water Maintenance Department has been working hard on repairing water main breaks and also repairing fire hydrants throughout the City. McCullough also stated that at the Clarifier Project has started at the Wastewater Treatment Plant.

AGENDA ITEM NO. 7: AUDIENCE PARTICIPATION

None

AGENDA ITEM NO. 8: ADJOURNMENT

Moved by Trustee Dowdell and seconded by Trustee Stewart to adjourn the meeting.

Chairman put the motion to a roll call vote:

Aye: Dowdell, Stewart, McComas, Jones, Berrong
Nay: None

Chairman declared the meeting adjourned at 5:40 p.m.

PUBLIC NOTICE OF MEETING

REGULAR MEETING OF CLINTON RECREATIONAL AUTHORITY

TUESDAY, SEPTEMBER 1, 2020

CLINTON CITY HALL

5:30 P.M.

AGENDA

- 1. Call to Order**
- 2. Opening Prayer/Pledge: Pat Peters, Church of Christ**
- 3. Consent Agenda**
 - A. Consider approval of Minutes of August 4, 2020**
 - B. Consider claims**
- 4. Action Items:**
- 5. Trustees Report**
- 6. City Manager's Report**
- 7. Adjournment**

Filed this _____ day of _____, 2020.

Posted on the bulletin board in the lobby of the Clinton City Hall on
_____, 2020, _____ A.M./P.M.

Debra Blanchard, Acting City Clerk

**MINUTES OF RECREATIONAL AUTHORITY MEETING
AUGUST 4, 2020**

Minutes of the regular meeting of the Chairman and Trustees of the Clinton Recreational Authority, City of Clinton, Oklahoma, Custer County, held in the City Council Room, City Hall on Tuesday, August 4, 2020, at 5:30 p.m. A notice of this meeting with agenda was posted on the bulletin board in the lobby of Clinton City Hall on Friday, July 31, 2020.

Chairman David Berrong called the meeting to order with the following present;

CHAIRMAN: David Berrong

TRUSTEES: Patch McComas, Ernie Dowdell, Bobby Stewart, Chris Jones

ACTING CITY MANAGER: Gene McCullough

CITY TREASURER: Debra Blanchard

CITY ATTORNEY: Ryan Meacham

DEPUTY TREASURER: Shona Stermer

NEWS MEDIA: Rod Serfoss and Mike Smith

OTHERS: Paul Rinkel, Donnie Phipps, Gary Kluckner, Pat Peters, Rhonda Williams

Pat Peters opened the meeting with prayer and Trustee Bobby Stewart led the Pledge of Allegiance.

AGENDA ITEM NO. 3: CONSENT AGENDA

- A. Minutes of Regular Meeting of July 7, 2020
- B. Consider claims

Moved by Trustee Jones and seconded by Trustee Dowdell, that Consent Agenda Item No. 3 (a-b) be approved.

Chairman put the motion to a roll call vote:

Aye: Jones, Dowdell, Stewart, McComas, Berrong

Nay: None

Chairman declared the motion carried.

AGENDA ITEM NO. 4 ACTION ITEMS

None

AGENDA ITEM NO. 5 TRUSTEES REPORT

None

AGENDA ITEM NO. 6: CITY MANAGER'S REPORT

None

AGENDA ITEM NO. 7: AUDIENCE PARTICIPATION

None

AGENDA ITEM NO. 8: ADJOURNMENT

Moved by Trustee Dowdell and seconded by Trustee Jones to adjourn the meeting.

Chairman put the motion to a roll call vote:

Aye: Dowdell, Jones, Stewart, McComas, Berrong

Nay: None

Chairman declared the meeting adjourned at 5:32 p.m.

PUBLIC NOTICE OF MEETING
REGULAR MEETING OF SOLID WASTE AUTHORITY
TUESDAY, SEPTEMBER 1, 2020
CLINTON CITY HALL
5:30 P.M.

AGENDA

- 1. Call to Order**
- 2. Opening Prayer/Pledge: Pat Peters, Church of Christ**
- 3. Consent Agenda**
 - A. Consider approval of Minutes of August 4, 2020**
 - B. Consider Claims**
- 4. Action Items:**
- 5. Trustee Report**
- 6. City Manager's Report**
- 7. Adjournment**

Filed this _____ day of _____, 2020.

Posted on the bulletin board in the lobby of the Clinton City Hall on
_____, 2020, _____ A.M./P.M.

Debra Blanchard, Acting City Clerk

**MINUTES OF SOLID WASTE AUTHORITY MEETING
AUGUST 4, 2020**

Minutes of the regular meeting of the Chairman and Trustees of the Clinton Solid Waste Authority City of Clinton, Oklahoma, Custer County, held in the City Council Room, City Hall on Tuesday, August 4, 2020, at 5:30 p.m. A notice of this meeting with agenda was posted on the bulletin board in the lobby of Clinton City Hall on, Friday, July 31, 2020.

Chairman David Berrong called the meeting to order with the following present:

CHAIRMAN: David Berrong

TRUSTEES: Patch McComas, Ernie Dowdell, Bobby Stewart, Chris Jones

ACTING CITY MANAGER: Gene McCullough

CITY TREASURER: Debra Blanchard

CITY ATTORNEY: Ryan Meacham

DEPUTY TREASURER: Shona Stermer

NEWS MEDIA: Rod Serfoss and Mike Smith

OTHERS: Paul Rinkel, Donnie Phipps, Gary Kluckner, Pat Peters, Rhonda Williams

Pat Peters opened the meeting with prayer and Trustee Bobby Stewart led the Pledge of Allegiance.

AGENDA ITEM NO. 3: CONSENT AGENDA

- A. Minutes of Regular Meeting of July 7, 2020
- B. Consider claims

Moved by Trustee Jones and seconded by Trustee Dowdell that Consent Agenda Item No. 3 (a-b) be approved.

Chairman put the motion to a roll call vote:

Aye: Jones, Dowdell, Stewart, McComas, Berrong

Nay: None

Chairman declared the motion carried.

AGENDA ITEM NO. 4 ACTION ITEMS

4. CONSIDER AND TAKE ACTION ON PUBLIC WASTE CENTER RATE STABILIZATION

Acting City Manager, Gene McCullough, stated that the Solid Waste Department would like to have signage at the public waste center to show requirements and rates for dumping.

Solid Waste Supervisor, Donnie Phipps, stated that currently they haul off 6 roll offs a week. Phipps stated that he has contacted neighboring cities to see what their process and rates are for dumping. He also stated the signage would control the confusion at the public waste center.

McCullough stated the new rates to consider are as follows:

<u>COST FOR DUMPING TRASH</u>	<u>WITH CURRENT UTILL BILL/ID</u>	<u>WITHOUT</u>
MINIMUM LOAD	\$ 5.00	\$ 8.00
AVERAGE PICKUP LOAD	\$10.00	\$15.00
10FT TRAILER LOAD	\$20.00	\$30.00
16FT TRAILER LOAD	\$30.00	\$45.00
20FT TRAILER LOAD	\$40.00	\$60.00

COST FOR DUMPING TREE LIMBS/CLIPPINGS

COMMERCIAL/NON-RESIDENT

AVERAGE PICKUP LOAD	\$10.00
10FT TRAILER LOAD	\$20.00
16FT TRAILER LOAD	\$40.00
20FT TRAILER LOAD	\$60.00

Motion was made by Trustee McComas and seconded by Trustee Jones to table this action for the time being.

Chairman put the motion to a roll call vote:

Aye: McComas, Jones, Dowdell, Stewart, Berrong

Nay: None

Chairman declared the motion carried.

AGENDA ITEM NO. 5 TRUSTEES REPORT

Trustee Dowdell stated that the cemetery workers, David Snider and JW Fellows, do a great job keeping the cemetery looking nice.

AGENDA ITEM NO. 6: CITY MANAGER'S REPORT

None

AGENDA ITEM NO. 7: ADJOURNMENT

Moved by Trustee Dowdell and seconded by Trustee Stewart to adjourn the meeting.

Chairman put the motion to a roll call vote:

Aye: Dowdell, Stewart, Jones, McComas, Berrong

Nay: None

Chairman declared the meeting adjourned at 5:50 p.m.

**Clinton City Council meeting
Clinton City Hall
Council Chambers
Tuesday, September 1, 2020
5:30 p.m.**

PUBLIC NOTICE OF MEETING

REGULAR MEETING OF CLINTON CITY COUNCIL

TUESDAY, SEPTEMBER 1, 2020

CLINTON CITY HALL

5:30 P.M.

AGENDA

- 1. Call to Order**
- 2. Opening Prayer/Pledge**
- 3. Consent Agenda**
 - A. Consider minutes from August 18, 2020**
 - B. Consider claims**
- 4. Action Items:**
 - A. Consider and discuss, with reports from experts in our community, the status of COVID-19.**
 - B. Consider and take action on External Auditor Letter of Understanding/Engagement.**
 - C. Consider and take action on Inter-Local Agreement with Custer County.**
 - D. Consider and take action on easement agreement for utility construction.**
 - E. Consider and take action on Resolution No. 912 pertaining to CARES Act funds for public safety employees.**
 - F. Consider and take action on accepting award of CDBG grant for PAC System at Clinton Lake Plant project.**
 - G. Consider, discuss and act on adjourning to Executive Session for the purpose of Confidential Communication between the Board and its Attorney concerning a pending investigation, claim or action pursuant to 25 OS 307 (B)(4)**

**Clinton City Council meeting
Clinton City Hall
Council Chambers
Tuesday, September 1, 2020
5:30 p.m.**

H. Return to Open Session

**I. Consideration, discussion and possible action on any item
discussed in Executive Session.**

- 5. Council Report**
- 6 City Manager's Report**
- 7. Audience Participation**
- 8. Adjournment**

Filed this _____ day of _____, 2020.

**Posted on the bulletin board in the lobby of the Clinton City Hall on
_____, 2020, _____ A.M./P.M.**

Debra Blanchard, Acting City Clerk

**MINUTES OF THE CLINTON CITY COUNCIL
AUGUST 18, 2020**

Minutes of the regular meeting of the Mayor and Councilmen of the Clinton City Council, City of Clinton, Oklahoma, Custer County, held in the City Council Room, City Hall on Tuesday, August 18, 2020 at 5:30 p.m. A notice of this meeting with agenda was posted on the bulletin board in the lobby of Clinton City Hall on Friday, August 14, 2020.

Mayor David Berrong called the meeting to order with the following present:

MAYOR: David Berrong

COUNCILMEN: Patch McComas, Ernie Dowdell, Bobby Stewart, Chris Jones

ACTING CITY MANAGER: Gene McCullough

CITY TREASURER: Debra Blanchard

CITY ATTORNEY: Ryan Meacham

DEPUTY TREASURER: Shona Stermer

NEWS MEDIA: Rod Serfoss and Mike Smith

OTHERS: Paul Rinkel, Brett Russell, Mark Switzer, Toby Anders, Mr. & Mrs. Robert Johnston, Judy Stewart, Chris & Amy Fields, Ann Lambeth, Rhonda Williams and others.

Chris Fields opened the meeting with prayer and Trustee Bobby Stewart led the Pledge of Allegiance.

AGENDA ITEM NO. 3: CONSENT AGENDA

- A. Consider Minutes from August 4, 2020**
- B. Consider Minutes from Special Meeting on August 5, 2020**
- C. Consider Minutes from Special Meeting on August 7, 2020**
- D. Consider Minutes from Special meeting on August 13, 2020**

Motion was made by Councilman Jones and second by Councilman Dowdell that Consent Agenda Item No. 3 (a-d) be approved.

Mayor put the motion to a roll call vote:

Aye: Jones, Dowdell, Stewart, McComas, Berrong

Nay: None

Mayor declared the motion carried.

AGENDA ITEM NO. 4: ACTION ITEMS

4A. CONSIDER AND TAKE ACTION ON FINANCIAL CONSULTANT LETTER OF UNDERSTANDING/ENGAGEMENT WITH RS MEACHAM

Motion was made by Councilman Stewart and seconded by Councilman Dowdell to approve the service and reaffirm the contract with RS Meacham.

Mayor put the motion to a roll call vote:

Aye: Stewart, Dowdell, McComas, Jones, Berrong

Nay: None

Mayor declared the motion carried.

4B. CONSIDER AND TAKE ACTION ON ACME PARK DRAINAGE IMPROVEMENT PROJECT

Toby Anders presented Council with a new bid along with the previous bids Anders had acquired. After discussion between Anders and Council, the Council decided to table this to a later date. Council stated that they would like to see specs to compare the bids.

No action was taken.

4C. CONSIDER AND TAKE ACTION ON ACME RECREATION FACILITY REPAIRS DUE TO FLOODING

No action was taken.

4D. CONSIDER AND TAKE ACTION ON LETTER OF AGREEMENT WITH ACTION ASSOCIATES, INC. FOR 20-21 FISCAL YEAR

City Treasurer, Debra Blanchard explained that the City has had a letter of agreement with Action Associates, Inc. since FY 2004-2005.

Chief, Paul Rinkle, stated that he is on the Action Associates board and their program is an asset to the community.

Motion was made by Councilman Jones and seconded by Councilman Stewart to approve the Letter of Agreement with Action Associates, Inc. for 20-21 fiscal year.

Mayor put the motion to a roll call vote:

Aye: Jones, Stewart, Dowdell, McComas, Berrong
Nay: None

Mayor declared the motion carried.

AGENDA ITEM NO. 5: TRUSTEE REPORT

Mayor Berrong introduced the new City Manager and his wife, Mr. & Mrs. Robert B Johnston, to the City of Clinton.

AGENDA ITEM NO. 6: MANAGER'S REPORT

None

AGENDA ITEM NO. 7: AUDIENCE PARTICIPATION

None

AGENDA ITEM NO. 8: ADJOURNMENT

Motion made by Councilman McComas and second by Councilman Dowdell to adjourn the meeting.

Mayor put the motion to a roll call vote:

Aye: McComas, Dowdell, Jones, Stewart, Berrong

Nay: None

Mayor declared the meeting adjourned at 6:10 p.m.



Agenda Commentary

Item Title/ Subject: Discuss with local experts on COVID-19 status

Staff Source: Gene McCullough, Acting City Manager

Date: September 1, 2020

History/Background Information: The community is experiencing continued elevated infection numbers. The public school system has had to adjust schedules to keep everyone safe.

Subject Summary: A representative from the Clinton Public School administration will address the Council with updates on its status, as well as a representative from the medical community, Dr. Robert Blakeburn, to give the Council facts to consider.

Recommendation: None

Price/Cost: Unknown



Agenda Commentary

Item Title/ Subject: Consider Resolution for accepting funds from Cares Act for public safety personnel

Staff Source: Gene McCullough, Acting City Manager

Date: September 1, 2020

History/Background Information: The Cares Act is established to help fund costs related to COVID-19.

Subject Summary: A resolution approved by Council must be passed confirming the presumption of public safety personnel costs related to COVID-19 activities.

Recommendation: Approve Resolution No. 912

Price/Cost: Reimbursements for accrued costs.

**CITY OF CLINTON
CLINTON, OKLAHOMA**

RESOLUTION No. _____

A RESOLUTION CONCERNING FUNDING PURSUANT TO THE CARES ACT AND THE CORONAVIRUS RELIEF FUND, CONFIRMING THAT IT IS THE POLICY OF THE CITY THAT ALL PUBLIC SAFETY PERSONNEL COSTS ARE “SUBSTANTIALLY DEDICATED” TO THE COVID-19 RESPONSE EFFORTS OF THE CITY THROUGHOUT THE ONGOING STATE OF EMERGENCY.

WHEREAS, on March 11, 2020, the World Health Organization (WHO) declared the coronavirus COVID-19 disease to be a pandemic; and

WHEREAS, on March 13, 2020, the President of the United States declared a National Emergency; due to the COVID-19 Virus pandemic; and

WHEREAS, on March 15, 2020, the Governor of the State of Oklahoma declared an emergency caused by the impending threat of COVID-19 to the people of this State and the public’s peace, health and safety; and

WHEREAS, the Governor’s statewide emergency declaration has been renewed and extended numerous times and remains in effect; and

WHEREAS, it is the duty of the Mayor and City Council to protect the health and safety of the City and its inhabitants, to preserve the peace, and to provide civil defense and emergency functions; and

WHEREAS, the guidelines applicable to funding from the Cares Act indicate that there is a presumption that all public safety personnel costs are related to the COVID-19 relief efforts unless the relevant municipal official determines otherwise; and

WHEREAS, approval of this resolution is in the best interest of the residents of the City.

THEREFORE, BE IT RESOLVED by the City Council of the City of Clinton as follows:

- A. Pursuant to the guidelines established for the receipt by a municipality of funds pursuant to the Cares Act and the Coronavirus Relief Fund, the City Council confirms the presumption that all public safety personnel costs of the City for the period from March 1, 2020, through July 31, 2020, were substantially dedicated to the City’s COVID-19 response efforts.

B. City staff is authorized and directed to proceed with an application to the State of Oklahoma for reimbursement of COVID-19 related public safety personnel costs for the stated period.

C. The Mayor and/or City Manager are authorized to execute all documents necessary to complete the application and funding process.

This Resolution is approved in open meeting of the City of Clinton, Oklahoma, on the 1st day of September, 2020.

CITY OF CLINTON

David Berrong, Mayor

ATTEST:

City Clerk

Approved as to Form:

City Attorney



Agenda Commentary

Item Title/ Subject: External Auditor Letter of Understanding/Engagement

Staff Source: Debra Blanchard, City Treasurer

History/Background Information: The City retains a CPA as external auditor for the end of fiscal year required annual audit of financial reports.

Item/Subject Summary: Britton, Kuykendall, and Miller, CPAs have been our external auditor for many years. At the end of the fiscal year, the independent external auditors come in to complete the required annual audit of the financial statements. The firm is located in Weatherford and also performs audits for area school systems and counties.

Price/Cost: \$13,000

Recommendation: Continuation of the services provided by Britton, Kuykendall, and Miller, CPAs.



BRITTON, KUYKENDALL, & MILLER
CERTIFIED PUBLIC ACCOUNTANTS

JAMES M. KUYKENDALL
RICK D. MILLER

204 E. FRANKLIN - P.O. BOX 507
WEATHERFORD, OK 73096
580-772-3596
FAX 580-772-3085

June 9, 2020

To the City Council and Management
City of Clinton, Oklahoma
P.O. Box 1177
Clinton, OK 73601

We are pleased to confirm our understanding of the services we are to provide City of Clinton, Oklahoma for the year ended June 30, 2020. We will audit the financial statements of the governmental activities, the business-type activities, each major fund, and the aggregate remaining fund information, including the related notes to the financial statements, which collectively comprise the basic financial statements of City of Clinton, Oklahoma as of and for the year ended June 30, 2020. Accounting standards generally accepted in the United States of America provide for certain required supplementary information (RSI), such as management's discussion and analysis (MD&A), to supplement City of Clinton, Oklahoma's basic financial statements. Such information, although not a part of the basic financial statements, is required by the Governmental Accounting Standards Board who considers it to be an essential part of financial reporting for placing the basic financial statements in an appropriate operational, economic, or historical context. As part of our engagement, we will apply certain limited procedures to City of Clinton, Oklahoma's RSI in accordance with auditing standards generally accepted in the United States of America. These limited procedures will consist of inquiries of management regarding the methods of preparing the information and comparing the information for consistency with management's responses to our inquiries, the basic financial statements, and other knowledge we obtained during our audit of the basic financial statements. We will not express an opinion or provide any assurance on the information because the limited procedures do not provide us with sufficient evidence to express an opinion or provide any assurance. The following RSI is required by U.S. generally accepted accounting principles and will be subjected to certain limited procedures, but will not be audited:

- 1) Management's Discussion and Analysis.
- 2) Budgetary Comparison Schedules

We have also been engaged to report on supplementary information other than RSI that accompanies City of Clinton, Oklahoma's financial statements. We will subject the following supplementary information to the auditing procedures applied in our audit of the financial statements and certain additional procedures, including comparing and reconciling such information directly to the underlying accounting and other records used to prepare the financial statements or to the financial statements themselves, and other additional procedures in accordance with auditing standards generally accepted in the United States of America, and we will provide an opinion on it in relation to the financial statements as a whole in a report combined with our auditor's report on the financial statements:

- 1) Combining Financial Statements

Audit Objectives

The objective of our audit is the expression of opinions as to whether your financial statements are fairly presented, in all material respects, in conformity with U.S. generally accepted accounting principles and to report on the fairness of the supplementary information referred to in the second paragraph when considered in relation to the financial statements as a whole. Our audit will be conducted in accordance with auditing standards generally accepted in the United States of America and the standards for financial audits contained in *Government Auditing Standards*, issued by the Comptroller General of the United States, and will include tests of the accounting records of City of Clinton, Oklahoma and other procedures we consider necessary to enable us to express such opinions. We will issue a written report upon completion of our audit of City of Clinton, Oklahoma's financial statements. Our report will be addressed to management and the City Council of City of Clinton, Oklahoma. We cannot provide assurance that unmodified opinions will be expressed. Circumstances may arise in

which it is necessary for us to modify our opinions or add emphasis-of-matter or other-matter paragraphs. If our opinions are other than unmodified, we will discuss the reasons with you in advance. If, for any reason, we are unable to complete the audit or are unable to form or have not formed opinions, we may decline to express opinions or issue reports, or may withdraw from this engagement. If circumstances occur related to the condition of your records, the availability of sufficient, appropriate audit evidence, or the existence of a significant risk of material misstatement of the financial statements caused by error, fraudulent financial reporting, or misappropriation of assets, which in our professional judgment prevent us from completing the audit or forming an opinion on the financial statements, we retain the right to take any course of action permitted by professional standards, including declining to express an opinion or issue a report, or withdrawing from the engagement.

We will also provide a report (that does not include an opinion) on internal control related to the financial statements and compliance with the provisions of laws, regulations, contracts, and grant agreements, noncompliance with which could have a material effect on the financial statements as required by *Government Auditing Standards*. The report on internal control and on compliance and other matters will include a paragraph that states (1) that the purpose of the report is solely to describe the scope of testing of internal control and compliance, and the results of that testing, and not to provide an opinion on the effectiveness of the entity's internal control on compliance, and (2) that the report is an integral part of an audit performed in accordance with *Government Auditing Standards* in considering the entity's internal control and compliance. The paragraph will also state that the report is not suitable for any other purpose. If during our audit we become aware that City of Clinton, Oklahoma is subject to an audit requirement that is not encompassed in the terms of this engagement, we will communicate to management and those charged with governance that an audit in accordance with U.S. generally accepted auditing standards and the standards for financial audits contained in *Government Auditing Standards* may not satisfy the relevant legal, regulatory, or contractual requirements.

Audit Procedures - General

An audit includes examining, on a test basis, evidence supporting the amounts and disclosures in the financial statements; therefore, our audit will involve judgment about the number of transactions to be examined and the areas to be tested. An audit also includes evaluating the appropriateness of accounting policies used and the reasonableness of significant accounting estimates made by management, as well as evaluating the overall presentation of the financial statements. We will plan and perform the audit to obtain reasonable assurance about whether the financial statements are free of material misstatement, whether from (1) errors, (2) fraudulent financial reporting, (3) misappropriation of assets, or (4) violations of laws or governmental regulations that are attributable to the government or to acts by management or employees acting on behalf of the government. Because the determination of waste and abuse is subjective, *Government Auditing Standards* do not expect auditors to perform specific procedures to detect waste or abuse in financial audits nor do they expect auditors to provide reasonable assurance of detecting waste and abuse.

Because of the inherent limitations of an audit, combined with the inherent limitations of internal control, and because we will not perform a detailed examination of all transactions, an unavoidable risk exists that some material misstatements may exist and not be detected by us, even though the audit is properly planned and performed in accordance with U.S. generally accepted auditing standards and *Government Auditing Standards*. In addition, an audit is not designed to detect immaterial misstatements or violations of laws or governmental regulations that do not have a direct and material effect on the financial statements. However, we will inform the appropriate level of management of any material errors, fraudulent financial reporting, or misappropriation of assets that come to our attention. We will also inform the appropriate level of management of any violations of laws or governmental regulations that come to our attention, unless clearly inconsequential. Our responsibility as auditors is limited to the period covered by our audit and does not extend to later periods for which we are not engaged as auditors.

Our procedures will include tests of documentary evidence supporting the transactions recorded in the accounts, and may include tests of the physical existence of inventories, and direct confirmation of receivables and certain other assets and liabilities by correspondence with selected individuals, funding sources, creditors, and financial institutions. We may request written representations from your attorneys as part of the engagement, and they may bill you for responding to this inquiry. At the conclusion of our audit, we will require certain written representations from you about your responsibilities for the financial statements; compliance with laws, regulations, contracts, and grant agreements; and other responsibilities required by generally accepted auditing standards.

Audit Procedures - Internal Control

Our audit will include obtaining an understanding of the government and its environment, including internal control, sufficient to assess the risks of material misstatement of the financial statements and to design the nature, timing, and extent of further audit procedures. Tests of controls may be performed to test the effectiveness of certain controls that we consider relevant to preventing and detecting errors and fraud that are material to the financial statements and to preventing and detecting misstatements resulting from illegal acts and other noncompliance matters that have a direct and material effect on the financial statements. Our tests, if performed, will be less in scope than would be necessary to render an opinion on internal control and, accordingly, no opinion will be expressed in our report on internal control issued pursuant to *Government Auditing Standards*.

An audit is not designed to provide assurance on internal control or to identify significant deficiencies or material weaknesses. Accordingly, we will express no such opinion. However, during the audit, we will communicate to management and those charged with governance internal control related matters that are required to be communicated under AICPA professional standards and *Government Auditing Standards*.

Audit Procedures - Compliance

As part of obtaining reasonable assurance about whether the financial statements are free of material misstatement, we will perform tests of City of Clinton, Oklahoma's compliance with the provisions of applicable laws, regulations, contracts, agreements, and grants. However, the objective of our audit will not be to provide an opinion on overall compliance and we will not express such an opinion in our report on compliance issued pursuant to *Government Auditing Standards*.

Management Responsibilities

Management is responsible for designing, implementing, establishing, and maintaining effective internal controls relevant to the preparation and fair presentation of financial statements that are free from material misstatement, whether due to fraud or error, and for evaluating and monitoring ongoing activities to help ensure that appropriate goals and objectives are met; following laws and regulations; and ensuring that management and financial information is reliable and properly reported. Management is also responsible for implementing systems designed to achieve compliance with applicable laws, regulations, contracts, and grant agreements. You are also responsible for the selection and application of accounting principles, for the preparation and fair presentation of the financial statements and all accompanying information in conformity with U.S. generally accepted accounting principles, and for compliance with applicable laws and regulations and the provisions of contracts and grant agreements.

Management is also responsible for making all financial records and related information available to us and for the accuracy and completeness of that information. You are also responsible for providing us with (1) access to all information of which you are aware that is relevant to the preparation and fair presentation of the financial statements, including identification of all related parties and all related-party relationships and transactions, (2) additional information that we may request for the purpose of the audit, and (3) unrestricted access to persons within the government from whom we determine it necessary to obtain audit evidence.

Your responsibilities include adjusting the financial statements to correct material misstatements and for confirming to us in the written representation letter that the effects of any uncorrected misstatements aggregated by us during the current engagement and pertaining to the latest period presented are immaterial, both individually and in the aggregate, to the financial statements of each opinion unit taken as a whole.

You are responsible for the design and implementation of programs and controls to prevent and detect fraud, and for informing us about all known or suspected fraud affecting the government involving (1) management, (2) employees who have significant roles in internal control, and (3) others where the fraud could have a material effect on the financial statements. Your responsibilities include informing us of your knowledge of any allegations of fraud or suspected fraud affecting the government received in communications from employees, former employees, grantors, regulators, or others. In addition, you are responsible for identifying and ensuring that the government complies with applicable laws, regulations, contracts, agreements, and grants and for taking timely and appropriate steps to remedy fraud and noncompliance with provisions of laws, regulations, or contracts or grant agreements that we report.

With regard to including the auditor's report in an exempt offering document, you agree that the aforementioned auditor's report, or reference to Britton, Kuykendall & Miller, CPA's, will not be included in any such offering document without our prior permission or consent. Any agreement to perform work in connection with an exempt offering document, including an agreement to provide permission or consent, will be a separate engagement. With regard to an exempt offering document with which Britton, Kuykendall & Miller, CPA's is not involved, you agree to clearly indicate in the exempt offering document that Britton, Kuykendall & Miller, CPA's is not involved with the contents of such offering document.

You are responsible for the preparation of the supplementary information, which we have been engaged to report on, in conformity with U.S. generally accepted accounting principles. You agree to include our report on the supplementary information in any document that contains and indicates that we have reported on the supplementary information. You also agree to include the audited financial statements with any presentation of the supplementary information that includes our report thereon OR make the audited financial statements readily available to users of the supplementary information no later than the date the supplementary information is issued with our report thereon. Your responsibilities include acknowledging to us in the written representation letter that (1) you are responsible for presentation of the supplementary information in accordance with GAAP; (2) you believe the supplementary information, including its form and content, is fairly presented in accordance with GAAP; (3) the methods of measurement or presentation have not changed from those used in the prior period (or, if they have changed, the reasons for such changes); and (4) you have disclosed to us any significant assumptions or interpretations underlying the measurement or presentation of the supplementary information.

Management is responsible for establishing and maintaining a process for tracking the status of audit findings and recommendations. Management is also responsible for identifying and providing report copies of previous financial audits, attestation engagements, performance audits or other studies related to the objectives discussed in the Audit Objectives section of this letter. This responsibility includes relaying to us corrective actions taken to address significant findings and recommendations resulting from those audits, attestation engagements, performance audits, or other studies. You are also responsible for providing management's views on our current findings, conclusions, and recommendations, as well as your planned corrective actions, for the report, and for the timing and format for providing that information.

With regard to the electronic dissemination of audited financial statements, including financial statements published electronically on your website, you understand that electronic sites are a means to distribute information and, therefore, we are not required to read the information contained in these sites or to consider the consistency of other information in the electronic site with the original document.

In connection with this engagement, we may communicate with you or others via email transmission. As emails can be intercepted and read, disclosed, or otherwise used or communicated by an unintended third party, or may not be delivered to each of the parties to whom they are directed and only to such parties, we cannot guarantee or warrant that emails from us will be properly delivered and read only by the addressee. Therefore, we specifically disclaim and waive any liability or responsibility whatsoever for interception or unintentional disclosure of emails transmitted by us in connection with the performance of this engagement. In that regard, you agree that we shall have no liability for any loss or damage to any person or entity resulting from the use of email transmissions, including any consequential, incidental, direct, indirect, or special damages, such as loss of revenues or anticipated profits, or disclosure or communication of confidential or proprietary information.

Audit Administration, Fees, and Other

We understand that your employees will prepare all cash or other confirmations and schedules we request and will locate any documents selected by us for testing. We will schedule the engagement based in part on deadlines, working conditions, and the availability of your key personnel. We will plan the engagement based on the assumption that your personnel will cooperate and provide assistance by performing tasks such as preparing requested schedules, retrieving supporting documents, and preparing confirmations. If for whatever reason your personnel are unavailable to provide the necessary assistance in a timely manner, it may substantially increase the work we have to do to complete the engagement within the established deadlines, resulting in an increase in fees over our original fee estimate.

We will provide copies of our reports to the City; however, management is responsible for distribution of the reports and the financial statements. Unless restricted by law or regulation, or containing privileged and confidential information, copies of our reports are to be made available for public inspection.

The audit documentation for this engagement is the property of Britton, Kuykendall & Miller, CPA's and constitutes confidential information. However, subject to applicable laws and regulations, audit documentation and appropriate individuals will be made available upon request and in a timely manner to the Oklahoma State Auditor and Inspector or their designee, a federal agency providing direct or indirect funding, or the U.S. Government Accountability Office for purposes of a quality review of the audit, to resolve audit findings, or to carry out oversight responsibilities. We will notify you of any such request. If requested, access to such audit documentation will be provided under the supervision of Britton, Kuykendall & Miller personnel. Furthermore, upon request, we may provide copies of selected audit documentation to the aforementioned parties. These parties may intend, or decide, to distribute the copies or information contained therein to others, including other governmental agencies.

The audit documentation for this engagement will be retained for a minimum of five years after the report release date or for any additional period requested by the Oklahoma State Auditor and Inspector. If we are aware that a federal awarding agency or auditee is contesting an audit finding, we will contact the party(ies) contesting the audit finding for guidance prior to destroying the audit documentation.

James Kuykendall is the engagement partner and is responsible for supervising the engagement and signing the reports or authorizing another individual to sign them.

Our fee for these services will be at our standard hourly rates plus out-of-pocket costs (such as report reproduction, word processing, postage, travel, copies, telephone, etc.) except that we agree that our gross fee, including expenses, will not exceed \$13,000. Our standard hourly rates vary according to the degree of responsibility involved and the experience level of the personnel assigned to your audit. The above fee is based on anticipated cooperation from your personnel and the assumption that unexpected circumstances will not be encountered during the audit. If significant additional time is necessary, we will discuss it with you and arrive at a new fee estimate before we incur the additional costs.

Government Auditing Standards require that we provide you with a copy of our most recent external peer review report and any subsequent reports received during the contract period. Accordingly, our most recent peer review report accompanies this letter.

We appreciate the opportunity to be of service to City of Clinton, Oklahoma and believe this letter accurately summarizes the significant terms of our engagement. If you have any questions, please let us know. If you agree with the terms of our engagement as described in this letter, please sign the enclosed copy and return it to us.

Very truly yours,



BRITTON, KUYKENDALL & MILLER
Certified Public Accountants

RESPONSE:

This letter correctly sets forth the understanding of City of Clinton, Oklahoma.

Management signature: _____

Title: _____

Date: _____

Governance signature: _____

Title: _____

Date: _____



Agenda Commentary

Item Title/ Subject: Request for easements for utility line construction

Staff Source: Gene McCullough, Acting City Manager

Date: September 1, 2020

Subject Summary: A transmission line construction project is under way across property that the City of Clinton owns, and a request for easements as presented in the attached documents has been made to complete the project.

Recommendation: Approve the request for easement with Coates Field Services, representing Public Service Company of Oklahoma.

Price/Cost: \$2,000.00 payment for easement



An **AEP** Company

BOUNDLESS ENERGY™



March 25, 2020

City of Clinton
P.O. Box 1177
Clinton, OK 73601

Re: Clinton City – Weatherford City Transmission Line Project
Section 13, Township 12 North, Range 17 West
Custer County, Oklahoma

Dear Landowner:

You are receiving this letter because public records indicate you own property along a transmission line that needs to be rebuilt. Public Service Company of Oklahoma (PSO), in conjunction with AEP Oklahoma Transmission Company, Inc., wants to let you know about the project and how it impacts you and your property.

Coates Field Services is serving as PSO's right-of-way representative on this project and an agent will be contacting you about compensation for supplementing the current easement on your property. The discussion will include the offer from PSO for \$2,000.00 as payment for amending the existing easement on your property to bring the rights and restrictions to PSO's standard right-of-way requirements.

As a result of the COVID-19 pandemic and recommendations made by the Centers for Disease Control and Prevention (CDC), Coates Field Service right-of-way agents are limiting in-person visits with customers during this process to ensure the public's safety and health.

Prior to meeting with the right-of-way agent, please review the enclosed documents including the Easement, Survey Plat, Easement Payment Schedule, and W-9. Following contact with a right-of-way agent, please sign and date each document in the designated areas, have the Easement notarized and return all documents in the enclosed, stamped envelope. Once we receive the signed documents, a check will be issued to you in the amount of \$2,000.00 and sent to you along with a copy of the fully-executed, recorded Easement.

While PSO makes every effort to minimize disturbance during construction, there may be some impact to your property. When construction is complete, crews will return the property to as close to its original condition as possible.

If you have any questions about this process, please call me at (580) 467-8904 or email me at alex.gilmore@coatesfs.com. Thank you in advance for your prompt response.

Sincerely,

Alex Gilmore
Right-of-Way Agent
Coates Field Service, Inc. – Representing PSO

Enclosures:
Supplemental ROW Easement
Exhibit A Plat
Payment Schedule
W-9

Line Name: Clinton City - Weatherford City

Line No.: TLN114:00622 Easement No.: 55D

EASEMENT PAYMENT SCHEDULE

THE UNDERSIGNED:

GRANTOR: City of Clinton

ADDRESS: PO Box 1177, Clinton, Oklahoma 73601

HEREBY OFFER to accept amount as determined in accordance with the schedule below in full payment of the Easement and Right of Way for an electric transmission, distribution and communication lines, being, in, on, over, under, through and across the land of the Undersigned under an easement dated _____, 2020 from the Undersigned to the Company, to wit:

PAYMENT SCHEDULE

Easement Acquisition Cost Description:	Easement Paid	Damages Paid
Easement Consideration Paid - 0.657 Acres +/- @ \$2,000.00	\$ 2,000.00	
NW/4 of Section 13, Township No. 12 North, Range No. 17 West of the Indian Meridian, Tax Parcel Number 0000-13-012-017-B-000-50, Custer County, State of Oklahoma.		
Total Consideration includes Initial Consideration Paid	\$ 2,000.00	

The amounts so determined are full payment for the Easement and Right of Way. Any construction damages will be paid separately unless noted above.

Accepted on _____, 2020

Signed on _____, 2020

Coates Field Service, Inc. Contract Agent for:

GRANTOR: City of Clinton

Public Service Company of Oklahoma

By: _____

By: _____

Field Agent: _____

Signature of Authorized Signer

Print Name and Title

Attach Required W-9

For Office Use Only:

GL	PCBU	Project BPID	Work Order	Account	Dept.	CC	Act	ZIP CODE
114	TRANS	A16805132	42910603-03			942		73601

Line Name: Clinton City - Weatherford City
Line No.: TLN114:00622 **Easement No.:** 55A

SUPPLEMENTAL EASEMENT AND RIGHT-OF-WAY

THIS SUPPLEMENTAL EASEMENT AND RIGHT-OF-WAY is made by and between **City of Clinton**, whose address is P.O Box 1177, Clinton, OK 73601 ("Grantor"), whether one or more persons, and **Public Service Company of Oklahoma**, a(n) Oklahoma corporation, a unit of American Electric Power, whose principal business address is 1 Riverside Plaza, Columbus, Ohio 43215, ("AEP") ("Grantee").

WHEREAS, AEP has electrical facilities built upon a right of way across the property of the Grantor situated in the State of Oklahoma, Custer County, being the same premises as described in Book 201, Page 340 of the real property records of Custer County, Oklahoma, Tax Parcel Number 0000-13-012-017-B-000-50; which facilities have been in place since approximately 1928 ("Original Right of Way"); and

WHEREAS, Grantor is the successor in interest to all or part of the lands affected by the Original Right of Way.

NOW, THEREFORE, in consideration of the sum of Ten and NO/100 Dollars (\$10.00) and other good and valuable consideration, the receipt and sufficiency of which Grantor hereby acknowledges, Grantor hereby grants and conveys this Supplemental Easement and Right of Way to Grantee, its successors and assigns, for the purpose of electric transmission, distribution and communication facilities, in order to supplement and modify the original rights across Grantor's property situated in Custer County, Oklahoma, Section 13, Township 12 North, Range 17 West of the Indian Meridian, being the same premises described in Warranty Deed, recorded 09/12/1966 in Book 201, Page 340 as follows:

The location, width, and boundaries of the easement area are hereby revised, modified, and clarified to be as described and depicted on Exhibit A ("Easement Area"), attached hereto and made a part hereof.

The Easement is also supplemented by the addition of the following language:

Grantee, its successors and assigns, are granted the right to alter, construct, erect, improve, inspect, maintain, operate, patrol, protect, reconstruct, modify, add to, remove, repair, replace, upgrade and/or enlarge electric transmission and distribution facilities within the Easement Area.

The electric transmission and distribution facilities may consist of a variable number of towers or poles made of wood, metal, concrete, or other materials, crossarms, wires, guys, anchors, grounding systems, communication lines and associated fixtures, and may transmit electricity of any voltage or amperage; together with the right to add to said facilities from time to time, and the right to do anything necessary, useful, or convenient for the enjoyment of the Easement.

Grantee, its successors and assigns, are granted the right of unobstructed ingress and egress, at any and all times, on, over, under, across and upon the Easement Area, and across the adjoining lands of Grantor as necessary to access the Easement Area or structure locations for the above referenced purposes.

Grantee, its successors and assigns, shall have the right to cut down, trim, remove, and otherwise control, using herbicides or tree growth regulators, any trees, overhanging branches, vegetation, or brush within the Easement Area or situated on lands of Grantor that adjoin the Easement Area, when in the opinion of Grantee the vegetation may endanger the safety, or interfere with the construction, operation or maintenance, of Grantee's facilities or ingress or egress to, from or along the Easement Area.

In no event shall Grantor, its successors, assigns, agents, licensees, or legal representatives, plant or cultivate any trees; nor place, construct, install, erect or permit any temporary or permanent building, structure, improvement or obstruction, including but not limited to, storage tanks, billboards, signs, sheds, dumpsters, light poles, water impoundments, swimming pools or wells, or permit any alteration of the ground elevation, over or within the Easement Area. Grantee may, at Grantor's cost, remove any structure or obstruction if placed within the Easement Area, and may re-grade any alterations of the ground elevation within the Easement Area.

Grantor acknowledges that Grantee has explained the project to rebuild, alter, and upgrade the transmission line to Grantor, and Grantor's consent for such project is hereby granted.

Except as supplemented and amended herein, the original right of way shall remain in full force and effect.

This instrument may be executed simultaneously in two or more counterparts, each of which will be deemed an original, but all of which taken together will constitute one and the same instrument. The signature pages from each counterpart may be removed and attached to one document for purposes of recording this Supplemental Easement and Right of Way in the Official Public Records of Custer County, Oklahoma.

This instrument contains the agreement, expressed or implied, between the parties herein and shall inure to the benefit and be binding on their respective successors, assigns, heirs, executors, administrators, lessees, tenants, and licensees.

EXECUTED effective this _____ day of _____, 2020.

GRANTOR:
City of Clinton

By: _____

Its: _____

STATE OF OKLAHOMA §

COUNTY OF CUSTER §

The foregoing instrument was acknowledged before me this _____ day of _____, 2020, _____, _____, of City of Clinton, on behalf city.

Notary Public

My Commission Expires: _____

This instrument prepared by Thomas G. St. Pierre, Associate General Counsel - Real Estate, American Electric Power Service Corporation, 1 Riverside Plaza, Columbus, OH 43215 for and on behalf of **Public Service Company of Oklahoma**.

When recorded return to: American Electric Power - Transmission Right of Way, 212 E. 6th Street, Tulsa, OK 74119

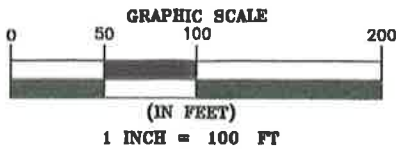
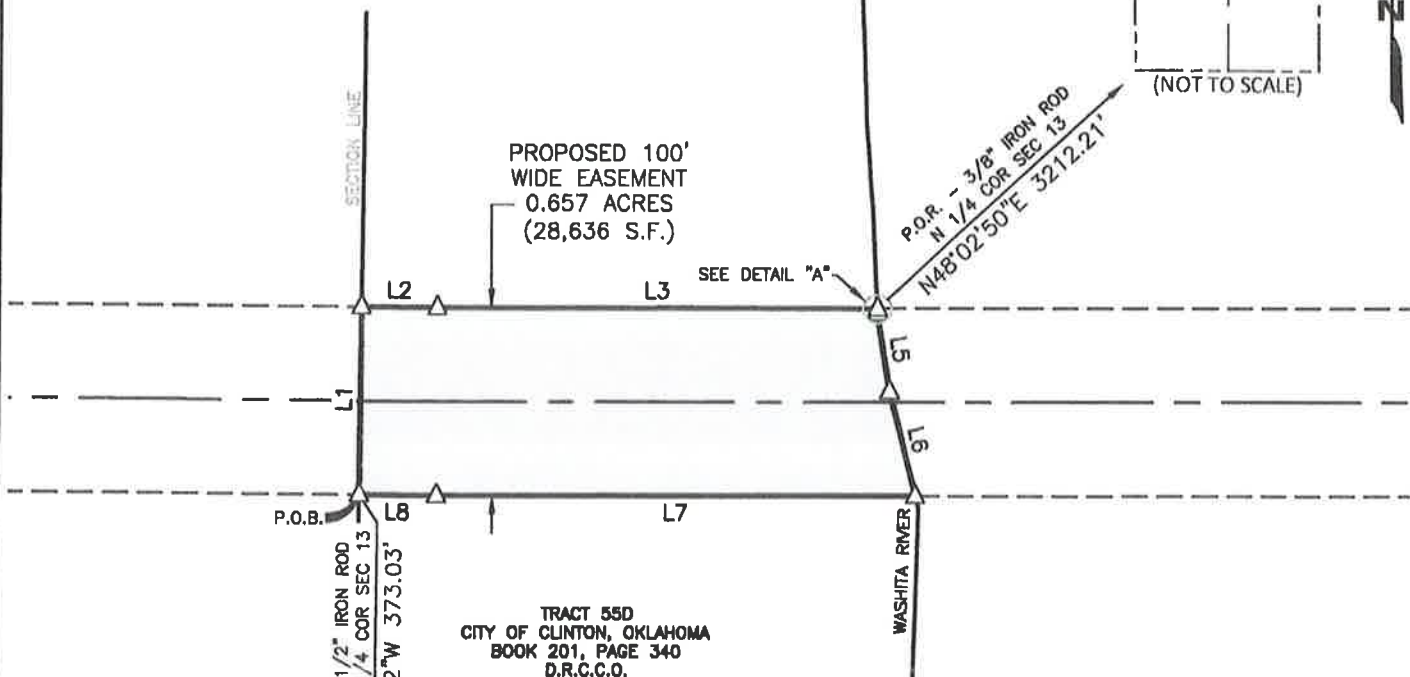

EXHIBIT "A"

TRACT 55D

VICINITY MAP SECTION 13



TRACT 55D
CITY OF CLINTON, OKLAHOMA
BOOK 201, PAGE 340
D.R.C.C.O.

SECTION 13
TOWNSHIP 12 NORTH
RANGE 17 WEST

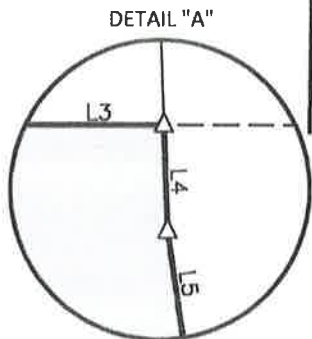

(NOT TO SCALE)

LINE TABLE		
NUMBER	BEARING	DISTANCE
L1	N00°38'32"E	100.00'
L2	S89°32'35"E	41.00'
L3	N89°55'10"E	235.84'
L4	S02°17'37"E	2.34'
L5	S08°48'37"E	42.72'
L6	S14°07'30"E	57.14'
L7	S89°55'10"W	256.75'
L8	N89°32'35"W	41.79'

LEGEND

- D.R.C.C.O. DEED RECORDS, CUSTER COUNTY, OKLAHOMA
- P.O.B. POINT OF BEGINNING
- P.O.R. POINT OF REFERENCE
- △ CALCULATED POINT
- SECTION LINE
- - - 1/4 SECTION LINE
- ==== SUBJECT PROPERTY LINE
- ==== PROPERTY LINE
- PROPOSED EASEMENT CENTERLINE
- PROPOSED EASEMENT
- ===== STATUTORY RIGHT OF WAY



Jason Sullivan 2/24/20

THIS SURVEY MEETS THE OKLAHOMA MINIMUM STANDARDS FOR THE PRACTICE OF LAND SURVEYING AS ESTABLISHED BY THE OKLAHOMA STATE BOARD OF PROFESSIONAL ENGINEERS AND LAND SURVEYORS

NOTES:

- THIS EXHIBIT DOES NOT REFLECT ANY UNDERGROUND UTILITIES, EASEMENTS OF RECORD OR OTHER ENCUMBRANCES THAT MAY AFFECT THE SUBJECT TRACT.
- REFERENCE IS MADE TO THE DESCRIPTION OF EVEN DATE ACCOMPANYING THIS SKETCH.
- BEARING BASIS: BEARINGS SHOWN HEREON ARE GRID, BASED ON THE OKLAHOMA STATE PLANE COORDINATE SYSTEM, NAD 83, NORTH ZONE.
- ALL DISTANCES SHOWN HEREON ARE SURFACE DISTANCES, DERIVED USING A COMBINED SCALE FACTOR OF 1.00006499035194

SHEET 01 OF 02

PROJECT: CLINTON CITY-WEATHERFORD CITY
JOB NUMBER: 51334
SITE VISIT: 12/04/2019
SCALE: 1"=100'
TRACT ID: 55D
DRAWN BY: CJC

PUBLIC SERVICE COMPANY OF OKLAHOMA
TRANSMISSION LINE EASEMENT
CLINTON CITY TO WEATHERFORD CITY
SECTION 13, TOWNSHIP 12 NORTH, RANGE 17 WEST
INDIAN MERIDIAN
CUSTER COUNTY, OKLAHOMA



7101 Envoy Court, Dallas, Tx 75247
Ph: (214) 631-7888 Fax: (214) 631-7103
E-MAIL: SAM@SAMRIZ
C.O.A. # 4216 EXPIRES 8/30/2021

EXHIBIT "A"

BEING A TRACT OF LAND SITUATED IN THE NORTHWEST 1/4 OF SECTION 13, TOWNSHIP 12 NORTH, RANGE 17 WEST OF THE INDIAN MERIDIAN, CUSTER COUNTY, OKLAHOMA AND BEING MORE PARTICULARLY DESCRIBED AS FOLLOWS:

BEGINNING AT A POINT ON THE WEST LINE OF SAID NORTHWEST 1/4, FROM WHICH A 1/2-INCH IRON ROD FOUND AT THE WEST 1/4 CORNER OF SAID SECTION 13 BEARS SOUTH 00 DEGREES 38 MINUTES 32 SECONDS WEST, A DISTANCE OF 373.03 FEET;

THENCE NORTH 00 DEGREES 38 MINUTES 32 SECONDS EAST, ON AND ALONG SAID WEST LINE, A DISTANCE OF 100.00 FEET TO A POINT FOR CORNER;

THENCE SOUTH 89 DEGREES 32 MINUTES 35 SECONDS EAST, LEAVING SAID WEST LINE, A DISTANCE OF 41.00 FEET TO A POINT FOR CORNER;

THENCE NORTH 89 DEGREES 55 MINUTES 10 SECONDS EAST, A DISTANCE OF 235.84 FEET TO THE WEST BANK OF THE WASHITA RIVER TO A POINT FOR CORNER, FROM WHICH A 3/8-INCH IRON ROD FOUND AT THE NORTH 1/4 CORNER OF SAID SECTION 13 BEARS NORTH 48 DEGREES 02 MINUTES 50 SECONDS EAST, A DISTANCE OF 3,212.21 FEET;

THENCE ON AND ALONG SAID WEST BANK THE FOLLOWING THREE (3) COURSES AND DISTANCES:

SOUTH 02 DEGREES 17 MINUTES 37 SECONDS EAST, A DISTANCE OF 2.34 FEET TO A POINT FOR CORNER;

SOUTH 08 DEGREES 48 MINUTES 37 SECONDS EAST, A DISTANCE OF 42.72 FEET TO A POINT FOR CORNER;

SOUTH 14 DEGREES 07 MINUTES 30 SECONDS EAST, A DISTANCE OF 57.14 FEET TO A POINT FOR CORNER;

THENCE SOUTH 89 DEGREES 55 MINUTES 10 SECONDS WEST, LEAVING SAID WEST BANK, A DISTANCE OF 256.75 FEET TO A POINT FOR CORNER;

THENCE SOUTH 89 DEGREES 32 MINUTES 35 SECONDS WEST, A DISTANCE OF 41.79 FEET, BACK TO THE POINT OF BEGINNING, CONTAINING 28,636 SQUARE FEET OR 0.657 OF AN ACRE OF LAND, MORE OR LESS.

BEARING BASIS: BEARINGS SHOWN HEREON ARE GRID, BASED ON THE OKLAHOMA STATE PLANE COORDINATE SYSTEM, NAD 83(2011), NORTH ZONE. ALL DISTANCES SHOWN HEREON ARE SURFACE DISTANCES, DERIVED USING A COMBINED SCALE FACTOR OF 1.00006499035194.

THIS SURVEY MEETS THE MINIMUM STANDARDS FOR THE PRACTICE OF LAND SURVEYING AS ADOPTED BY THE OKLAHOMA STATE BOARD OF PROFESSIONAL ENGINEERS AND LAND SURVEYORS.

Jason Sullivan 2/24/20
JASON SULLIVAN
PLS# 1791
SURVEYING AND MAPPING, L.L.C.



Line Name: Clinton City - Weatherford City
Line No.: TLN114:00622 **Easement No.:** 55A

SUPPLEMENTAL EASEMENT AND RIGHT-OF-WAY

THIS SUPPLEMENTAL EASEMENT AND RIGHT-OF-WAY is made by and between **City of Clinton**, whose address is P.O Box 1177, Clinton, OK 73601 ("Grantor"), whether one or more persons, and **Public Service Company of Oklahoma**, a(n) Oklahoma corporation, a unit of American Electric Power, whose principal business address is 1 Riverside Plaza, Columbus, Ohio 43215, ("AEP") ("Grantee").

WHEREAS, AEP has electrical facilities built upon a right of way across the property of the Grantor situated in the State of Oklahoma, Custer County, being the same premises as described in Book 201, Page 340 of the real property records of Custer County, Oklahoma, Tax Parcel Number 0000-13-012-017-B-000-50; which facilities have been in place since approximately 1928 ("Original Right of Way"); and

WHEREAS, Grantor is the successor in interest to all or part of the lands affected by the Original Right of Way.

NOW, THEREFORE, in consideration of the sum of Ten and NO/100 Dollars (\$10.00) and other good and valuable consideration, the receipt and sufficiency of which Grantor hereby acknowledges, Grantor hereby grants and conveys this Supplemental Easement and Right of Way to Grantee, its successors and assigns, for the purpose of electric transmission, distribution and communication facilities, in order to supplement and modify the original rights across Grantor's property situated in Custer County, Oklahoma, Section 13, Township 12 North, Range 17 West of the Indian Meridian, being the same premises described in Warranty Deed, recorded 09/12/1966 in Book 201, Page 340 as follows:

The location, width, and boundaries of the easement area are hereby revised, modified, and clarified to be as described and depicted on Exhibit A ("Easement Area"), attached hereto and made a part hereof.

The Easement is also supplemented by the addition of the following language:

Grantee, its successors and assigns, are granted the right to alter, construct, erect, improve, inspect, maintain, operate, patrol, protect, reconstruct, modify, add to, remove, repair, replace, upgrade and/or enlarge electric transmission and distribution facilities within the Easement Area.

The electric transmission and distribution facilities may consist of a variable number of towers or poles made of wood, metal, concrete, or other materials, crossarms, wires, guys, anchors, grounding systems, communication lines and associated fixtures, and may transmit electricity of any voltage or amperage; together with the right to add to said facilities from time to time, and the right to do anything necessary, useful, or convenient for the enjoyment of the Easement.

Grantee, its successors and assigns, are granted the right of unobstructed ingress and egress, at any and all times, on, over, under, across and upon the Easement Area, and across the adjoining lands of Grantor as necessary to access the Easement Area or structure locations for the above referenced purposes.

Grantee, its successors and assigns, shall have the right to cut down, trim, remove, and otherwise control, using herbicides or tree growth regulators, any trees, overhanging branches, vegetation, or brush within the Easement Area or situated on lands of Grantor that adjoin the Easement Area, when in the opinion of Grantee the vegetation may endanger the safety, or interfere with the construction, operation or maintenance, of Grantee's facilities or ingress or egress to, from or along the Easement Area.

In no event shall Grantor, its successors, assigns, agents, licensees, or legal representatives, plant or cultivate any trees; nor place, construct, install, erect or permit any temporary or permanent building, structure, improvement or obstruction, including but not limited to, storage tanks, billboards, signs, sheds, dumpsters, light poles, water impoundments, swimming pools or wells, or permit any alteration of the ground elevation, over or within the Easement Area. Grantee may, at Grantor's cost, remove any structure or obstruction if placed within the Easement Area, and may re-grade any alterations of the ground elevation within the Easement Area.

Grantor acknowledges that Grantee has explained the project to rebuild, alter, and upgrade the transmission line to Grantor, and Grantor's consent for such project is hereby granted.

Except as supplemented and amended herein, the original right of way shall remain in full force and effect.

This instrument may be executed simultaneously in two or more counterparts, each of which will be deemed an original, but all of which taken together will constitute one and the same instrument. The signature pages from each counterpart may be removed and attached to one document for purposes of recording this Supplemental Easement and Right of Way in the Official Public Records of Custer County, Oklahoma.

This instrument contains the agreement, expressed or implied, between the parties herein and shall inure to the benefit and be binding on their respective successors, assigns, heirs, executors, administrators, lessees, tenants, and licensees.

EXECUTED effective this _____ day of _____, 2020.

GRANTOR:
City of Clinton

By: _____

Its: _____

STATE OF OKLAHOMA §

COUNTY OF CUSTER §

The foregoing instrument was acknowledged before me this _____ day of _____, 2020, _____, _____, of City of Clinton, on behalf city.

Notary Public

My Commission Expires: _____

This instrument prepared by Thomas G. St. Pierre, Associate General Counsel - Real Estate, American Electric Power Service Corporation, 1 Riverside Plaza, Columbus, OH 43215 for and on behalf of **Public Service Company of Oklahoma.**

When recorded return to: American Electric Power - Transmission Right of Way, 212 E. 6th Street, Tulsa, OK 74119

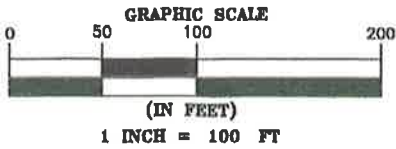
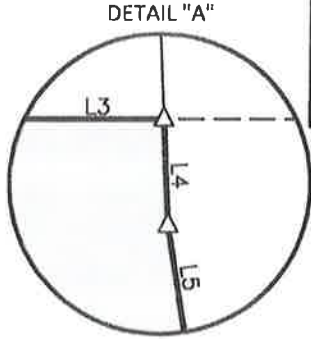
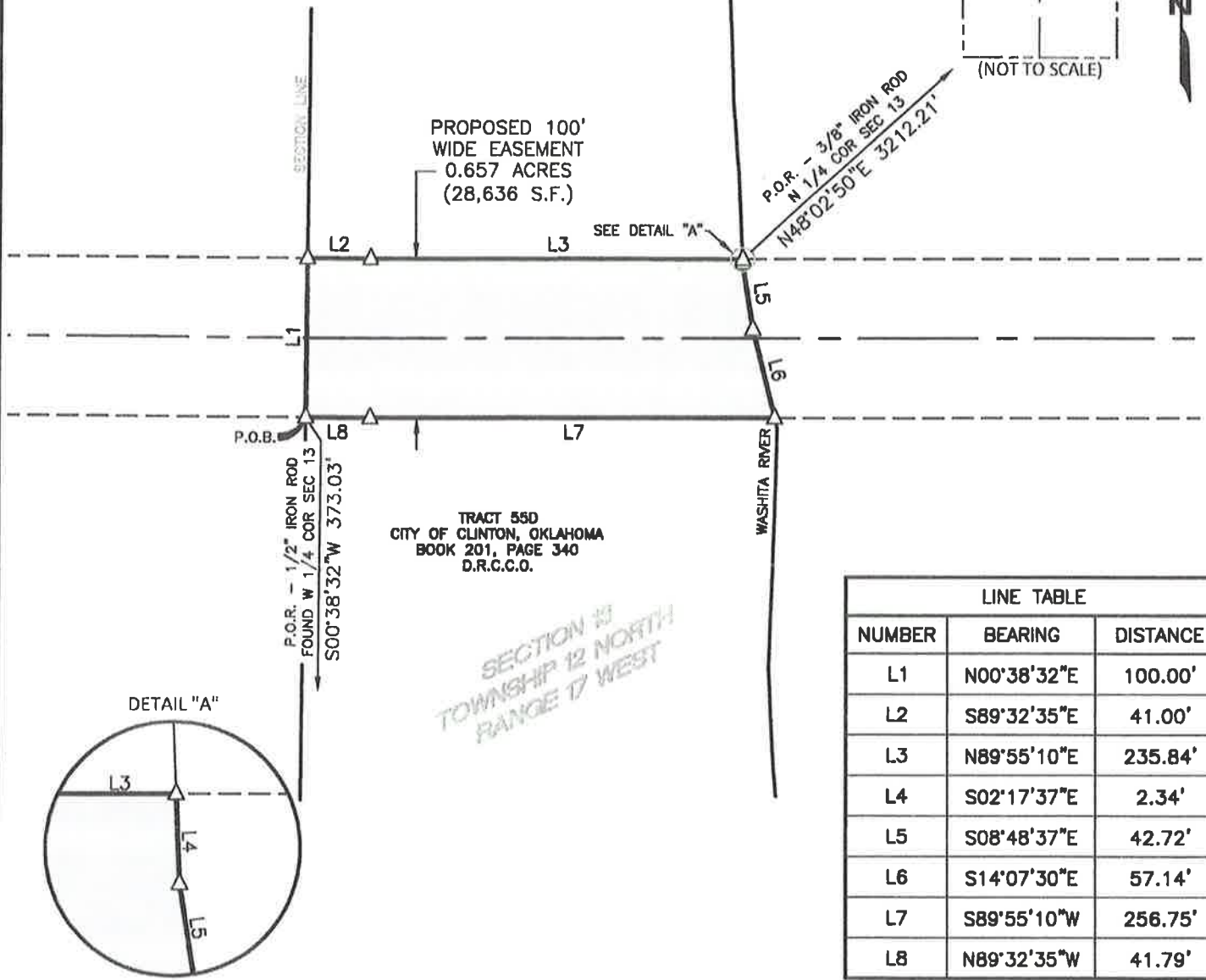
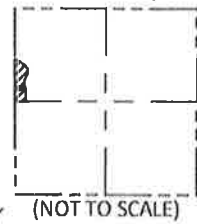

EXHIBIT "A"

TRACT 55D

VICINITY MAP
SECTION 13



(NOT TO SCALE)

LINE TABLE		
NUMBER	BEARING	DISTANCE
L1	N00°38'32"E	100.00'
L2	S89°32'35"E	41.00'
L3	N89°55'10"E	235.84'
L4	S02°17'37"E	2.34'
L5	S08°48'37"E	42.72'
L6	S14°07'30"E	57.14'
L7	S89°55'10"W	256.75'
L8	N89°32'35"W	41.79'

LEGEND

- D.R.C.C.O. DEED RECORDS, CUSTER COUNTY, OKLAHOMA
- P.O.B. POINT OF BEGINNING
- P.O.R. POINT OF REFERENCE
- △ CALCULATED POINT
- SECTION LINE
- 1/4 SECTION LINE
- SUBJECT PROPERTY LINE
- PROPERTY LINE
- PROPOSED EASEMENT CENTERLINE
- PROPOSED EASEMENT
- STATUTORY RIGHT OF WAY



Jason Sullivan 2/24/20

THIS SURVEY MEETS THE OKLAHOMA MINIMUM STANDARDS FOR THE PRACTICE OF LAND SURVEYING AS ESTABLISHED BY THE OKLAHOMA STATE BOARD OF PROFESSIONAL ENGINEERS AND LAND SURVEYORS

NOTES:

1. THIS EXHIBIT DOES NOT REFLECT ANY UNDERGROUND UTILITIES, EASEMENTS OF RECORD OR OTHER ENCUMBRANCES THAT MAY AFFECT THE SUBJECT TRACT.
2. REFERENCE IS MADE TO THE DESCRIPTION OF EVEN DATE ACCOMPANYING THIS SKETCH.
3. BEARING BASIS: BEARINGS SHOWN HEREON ARE GRID, BASED ON THE OKLAHOMA STATE PLANE COORDINATE SYSTEM, NAD 83, NORTH ZONE.
4. ALL DISTANCES SHOWN HEREON ARE SURFACE DISTANCES, DERIVED USING A COMBINED SCALE FACTOR OF 1.00006499035194

SHEET 01 OF 02

PROJECT: CLINTON CITY-WEATHERFORD CITY
JOB NUMBER: 51334
SITE VISIT: 12/04/2019
SCALE: 1"=100'
TRACT ID: 55D
DRAWN BY: CJC

PUBLIC SERVICE COMPANY OF OKLAHOMA
TRANSMISSION LINE EASEMENT
CLINTON CITY TO WEATHERFORD CITY
SECTION 13, TOWNSHIP 12 NORTH, RANGE 17 WEST
INDIAN MERIDIAN
CUSTER COUNTY, OKLAHOMA



7101 Envoy Court, Dallas, Tx 75247
Ph: (214) 631-7888 Fax: (214) 631-7103
E-MAIL: SAM@SAM.FLZ
C.O.A. # 4216 EXPIRES: 6/30/2021

EXHIBIT "A"

BEING A TRACT OF LAND SITUATED IN THE NORTHWEST 1/4 OF SECTION 13, TOWNSHIP 12 NORTH, RANGE 17 WEST OF THE INDIAN MERIDIAN, CUSTER COUNTY, OKLAHOMA AND BEING MORE PARTICULARLY DESCRIBED AS FOLLOWS:

BEGINNING AT A POINT ON THE WEST LINE OF SAID NORTHWEST 1/4, FROM WHICH A 1/2-INCH IRON ROD FOUND AT THE WEST 1/4 CORNER OF SAID SECTION 13 BEARS SOUTH 00 DEGREES 38 MINUTES 32 SECONDS WEST, A DISTANCE OF 373.03 FEET;

THENCE NORTH 00 DEGREES 38 MINUTES 32 SECONDS EAST, ON AND ALONG SAID WEST LINE, A DISTANCE OF 100.00 FEET TO A POINT FOR CORNER;

THENCE SOUTH 89 DEGREES 32 MINUTES 35 SECONDS EAST, LEAVING SAID WEST LINE, A DISTANCE OF 41.00 FEET TO A POINT FOR CORNER;

THENCE NORTH 89 DEGREES 55 MINUTES 10 SECONDS EAST, A DISTANCE OF 235.84 FEET TO THE WEST BANK OF THE WASHITA RIVER TO A POINT FOR CORNER, FROM WHICH A 3/8-INCH IRON ROD FOUND AT THE NORTH 1/4 CORNER OF SAID SECTION 13 BEARS NORTH 48 DEGREES 02 MINUTES 50 SECONDS EAST, A DISTANCE OF 3,212.21 FEET;

THENCE ON AND ALONG SAID WEST BANK THE FOLLOWING THREE (3) COURSES AND DISTANCES:

SOUTH 02 DEGREES 17 MINUTES 37 SECONDS EAST, A DISTANCE OF 2.34 FEET TO A POINT FOR CORNER;

SOUTH 08 DEGREES 48 MINUTES 37 SECONDS EAST, A DISTANCE OF 42.72 FEET TO A POINT FOR CORNER;

SOUTH 14 DEGREES 07 MINUTES 30 SECONDS EAST, A DISTANCE OF 57.14 FEET TO A POINT FOR CORNER;

THENCE SOUTH 89 DEGREES 55 MINUTES 10 SECONDS WEST, LEAVING SAID WEST BANK, A DISTANCE OF 256.75 FEET TO A POINT FOR CORNER;

THENCE SOUTH 89 DEGREES 32 MINUTES 35 SECONDS WEST, A DISTANCE OF 41.79 FEET, BACK TO THE POINT OF BEGINNING, CONTAINING 28,636 SQUARE FEET OR 0.657 OF AN ACRE OF LAND, MORE OR LESS.

BEARING BASIS: BEARINGS SHOWN HEREON ARE GRID, BASED ON THE OKLAHOMA STATE PLANE COORDINATE SYSTEM, NAD 83(2011), NORTH ZONE. ALL DISTANCES SHOWN HEREON ARE SURFACE DISTANCES, DERIVED USING A COMBINED SCALE FACTOR OF 1.00006499035194.

THIS SURVEY MEETS THE MINIMUM STANDARDS FOR THE PRACTICE OF LAND SURVEYING AS ADOPTED BY THE OKLAHOMA STATE BOARD OF PROFESSIONAL ENGINEERS AND LAND SURVEYORS.

 2/24/20
JASON SULLIVAN
PLS# 1791
SURVEYING AND MAPPING, LLC.



Request for Taxpayer Identification Number and Certification

**Give Form to the
 requester. Do not
 send to the IRS.**

▶ Go to www.irs.gov/FormW9 for instructions and the latest information.

Print or type.
 See Specific Instructions on page 3.

1 Name (as shown on your income tax return). Name is required on this line; do not leave this line blank.	
2 Business name/disregarded entity name, if different from above	
3 Check appropriate box for federal tax classification of the person whose name is entered on line 1. Check only one of the following seven boxes. <input type="checkbox"/> Individual/sole proprietor or single-member LLC <input type="checkbox"/> C Corporation <input type="checkbox"/> S Corporation <input type="checkbox"/> Partnership <input type="checkbox"/> Trust/estate <input type="checkbox"/> Limited liability company. Enter the tax classification (C=C corporation, S=S corporation, P=Partnership) ▶ _____ Note: Check the appropriate box in the line above for the tax classification of the single-member owner. Do not check LLC if the LLC is classified as a single-member LLC that is disregarded from the owner unless the owner of the LLC is another LLC that is not disregarded from the owner for U.S. federal tax purposes. Otherwise, a single-member LLC that is disregarded from the owner should check the appropriate box for the tax classification of its owner. <input type="checkbox"/> Other (see instructions) ▶ _____	4 Exemptions (codes apply only to certain entities, not individuals; see instructions on page 3): Exempt payee code (if any) _____ Exemption from FATCA reporting code (if any) _____ <small>(Applies to accounts maintained outside the U.S.)</small>
5 Address (number, street, and apt. or suite no.) See instructions.	Requester's name and address (optional)
6 City, state, and ZIP code	
7 List account number(s) here (optional)	

Part I Taxpayer Identification Number (TIN)

Enter your TIN in the appropriate box. The TIN provided must match the name given on line 1 to avoid backup withholding. For individuals, this is generally your social security number (SSN). However, for a resident alien, sole proprietor, or disregarded entity, see the instructions for Part I, later. For other entities, it is your employer identification number (EIN). If you do not have a number, see *How to get a TIN*, later.

Note: If the account is in more than one name, see the instructions for line 1. Also see *What Name and Number To Give the Requester* for guidelines on whose number to enter.

Social security number								
<table style="width: 100%; border-collapse: collapse;"> <tr> <td style="width: 25%; border: 1px solid black; height: 20px;"></td> <td style="width: 25%; border: 1px solid black; height: 20px;"></td> <td style="width: 25%; border: 1px solid black; height: 20px;"></td> <td style="width: 25%; border: 1px solid black; height: 20px;"></td> </tr> <tr> <td style="text-align: center;">-</td> <td style="text-align: center;">-</td> <td></td> <td></td> </tr> </table>					-	-		
-	-							
or								
Employer identification number								
<table style="width: 100%; border-collapse: collapse;"> <tr> <td style="width: 25%; border: 1px solid black; height: 20px;"></td> <td style="width: 25%; border: 1px solid black; height: 20px;"></td> <td style="width: 25%; border: 1px solid black; height: 20px;"></td> <td style="width: 25%; border: 1px solid black; height: 20px;"></td> </tr> <tr> <td style="text-align: center;">-</td> <td style="text-align: center;">-</td> <td></td> <td></td> </tr> </table>					-	-		
-	-							

Part II Certification

Under penalties of perjury, I certify that:

1. The number shown on this form is my correct taxpayer identification number (or I am waiting for a number to be issued to me); and
2. I am not subject to backup withholding because: (a) I am exempt from backup withholding, or (b) I have not been notified by the Internal Revenue Service (IRS) that I am subject to backup withholding as a result of a failure to report all interest or dividends, or (c) the IRS has notified me that I am no longer subject to backup withholding; and
3. I am a U.S. citizen or other U.S. person (defined below); and
4. The FATCA code(s) entered on this form (if any) indicating that I am exempt from FATCA reporting is correct.

Certification instructions. You must cross out item 2 above if you have been notified by the IRS that you are currently subject to backup withholding because you have failed to report all interest and dividends on your tax return. For real estate transactions, item 2 does not apply. For mortgage interest paid, acquisition or abandonment of secured property, cancellation of debt, contributions to an individual retirement arrangement (IRA), and generally, payments other than interest and dividends, you are not required to sign the certification, but you must provide your correct TIN. See the instructions for Part II, later.

Sign Here

Signature of U.S. person ▶

Date ▶

General Instructions

Section references are to the Internal Revenue Code unless otherwise noted.

Future developments. For the latest information about developments related to Form W-9 and its instructions, such as legislation enacted after they were published, go to www.irs.gov/FormW9.

Purpose of Form

An individual or entity (Form W-9 requester) who is required to file an information return with the IRS must obtain your correct taxpayer identification number (TIN) which may be your social security number (SSN), individual taxpayer identification number (ITIN), adoption taxpayer identification number (ATIN), or employer identification number (EIN), to report on an information return the amount paid to you, or other amount reportable on an information return. Examples of information returns include, but are not limited to, the following.

- Form 1099-INT (interest earned or paid)

- Form 1099-DIV (dividends, including those from stocks or mutual funds)
- Form 1099-MISC (various types of income, prizes, awards, or gross proceeds)
- Form 1099-B (stock or mutual fund sales and certain other transactions by brokers)
- Form 1099-S (proceeds from real estate transactions)
- Form 1099-K (merchant card and third party network transactions)
- Form 1098 (home mortgage interest), 1098-E (student loan interest), 1098-T (tuition)
- Form 1099-C (canceled debt)
- Form 1099-A (acquisition or abandonment of secured property)

Use Form W-9 only if you are a U.S. person (including a resident alien), to provide your correct TIN.

If you do not return Form W-9 to the requester with a TIN, you might be subject to backup withholding. See What is backup withholding, later.



Agenda Commentary

Item Title/ Subject: CDBG Grant Award Acceptance

Staff Source: Gene McCullough, Acting City Manager

Date: September 1, 2020

History/Background Information: CDBG is administered in our area by SWODA. The City of Clinton applied for a grant for the PAC Filter System project at the Clinton Lake Plant facility.

Subject Summary: The City of Clinton has been awarded the applied for grant and requires acceptance from the Council to proceed with the project and allow the City to receive funds from the grant.

Recommendation:

Price/Cost: The PAC Filter System project will cost the City approximately \$1,199,000 (estimated) for total project with grant funds of \$450,000 and City funds of \$749,000.

17852 CDBG 20

FAIN #: B-20-DC-40-0001

UEI #:

FEI #: 736005149

CONTRACT PART I SUMMARY AND SIGNATURES

Contracting Agency: Oklahoma Department of Commerce State of Oklahoma (ODOC)
Contractor: City of Clinton
Contract Title: ODOC Community Development Block Grant
Contract Number: 17852 CDBG 20
Federal Amount: \$0
Match Amount: \$0
Contract Amount: \$450,000.00
Research and Development:
Indirect Cost Rate: 23.49
Grant Award Amount - This Action: \$450,000.00
Total Committed: \$450,000.00
Total Obligated: \$450,000.00
Source: U.S. Department of Housing and Urban Development (HUD) Catalog of Federal Domestic Assistance (CFDA) Number 14.228
Project Funding Period: August 3, 2020 through August 2, 2022
Federal Award Period: May 6, 2020 through May 5, 2027
Summary of Project

Budget Summary

Table with 2 columns: Category and Amount. Rows include Construction, Engineering/Architect, Inspection, Other, Public Facilities Admin, Direct Grantee Admin, Planning, TOTAL CDBG, TOTAL LEVERAGE, and TOTAL FUNDS.

Submit Requisitions to: Community Development Oklahoma Department of Commerce 900 North Stiles Oklahoma City, OK 73104-3234
Issue Payment To: City of Clinton P.O. Box 1177 Clinton, OK 73601-1177

AGREEMENT COMPONENTS Part I - Summary and Signatures Part II -

17852 CDBG 20

Terms and Conditions
Certification Regarding Lobbying

SPECIAL CONDITIONS:

SIGNATURES – EXECUTION OF CONTRACT

The rights and obligations of the parties to this contract are subject to and governed by Part II – Terms and Conditions. To the extent of any inconsistency between the general and the specific, the specific governs.

I certify that I am authorized to sign this document, and any attachments or addendums thereto, and I have read and agree to all parts of the contract.

Executed by:City of Clinton

Executed by:Oklahoma Department of
Commerce

Signature of Authorized Official

Signature of Authorized ODOC Official

Date

Date



PART II - TERMS AND CONDITIONS

1. AVAILABILITY OF FUNDS

Payments pursuant to this contract are to be made only from monies made available to the Oklahoma Department of Commerce (ODOC) by the U.S. Department of Housing and Urban Development (HUD) for the CDBG Program for non-entitlement areas. Notwithstanding any other provisions, payments to the Contractor by ODOC are subject to the availability of such funds to ODOC as determined by federal and/or State action and/or law. ODOC may take any action necessary in accord with such determination.

2. MODIFICATION AMENDMENT

- A. This contract is subject to such modification as may be required by federal or State law or regulations. Any such modification may be done unilaterally by ODOC.
- B. Except as otherwise provided in this contract, the work and services to be performed and the total contract amount may be modified only upon following the process required by ODOC in accessing the OKGrants system.
- C. Revisions to the contract and the approved budget, which is a part of this contract, must follow the process required by ODOC in accessing the OKGrants system.
- D. A waiver by ODOC of any provision of this contract must follow the process required by ODOC in accessing the OKGrants system.

3. ODOC

- A. ODOC will provide funding for the project up to the total amount listed in Part I: Total Project Funding.
- B. ODOC shall perform monitoring to assess the Contractor's financial and program compliance and progress but said monitoring and evaluation shall not relieve the Contractor of any obligation or duty under this contract.

4. CONTRACTOR

- A. The Contractor agrees to perform those duties, obligations and representations contained in its application and to be bound by the provisions of its application, all amendments thereto and all correspondence relating thereto, which were submitted to and accepted by ODOC in contemplation of this contract, said application being incorporated herein and made apart hereof by reference. Any conflict between said application, amendments and correspondence and the provisions of this contract shall be controlled by this contract.
- B. None of the work and services covered by this contract may be subcontracted without prior written approval of ODOC. All compensated administrative consultants engaged by the Contractor must be ODOC Certified CDBG Administrators. However, said



determination by ODOC shall not relieve the Contractor of independent obligation to ensure that such persons are fully qualified, and able to perform the duties they have contracted to perform.

- C. In no event will any subcontractor subcontract or incur obligation on the part of ODOC.
 - D. The Contractor shall comply with all requirements of the ODOC CDBG Project Management Guide. The Guide is hereby annexed, incorporated, and made a part of this contract. The Guide may be amended during the current contract year by ODOC. When changes are made to the Project Management Guide, all certified CDBG grant administrators are notified by email that there have been updates to the Guide.
 - E. The Contractor shall commence actual construction or otherwise begin implementation of the funded project within two hundred seventy (270) days from the start date of the contract.
 - F. Based upon a Risk Assessment the ODOC may schedule mandatory Technical Assistance meetings. The Contractor shall ensure the attendance of any person performing services under this contract whose presence is requested.
5. 2 CFR 200.331

Pursuant to 2 CFR 200.331 - All pass-through entities must:

- A. Ensure that every subaward is clearly identified to the subrecipient as a subaward and includes the following information at the time of the subaward and if any of these data elements change, include the changes in subsequent subaward modification. When some of this information is not available, the pass-through entity must provide the best information available to describe the Federal award and subaward. Required information includes:
 - (1) Federal Award Identification.
 - (a) Subrecipient name (which must match the name associated with its unique entity identifier);
 - (b) Subrecipient's unique entity identifier;
 - (c) Federal Award Identification Number (FAIN);
 - (d) Federal Award Date (see §200.39 Federal award date) of award to the recipient by the Federal agency;
 - (e) Subaward Period of Performance Start and End Date;
 - (f) Amount of Federal Funds Obligated by this action by the pass-through entity to the subrecipient;
 - (g) Total Amount of Federal Funds Obligated to the subrecipient by the pass-through entity including the current obligation;
 - (h) Total Amount of the Federal Award committed to the subrecipient by the pass-through entity;



- (i) Federal award project description, as required to be responsive to the Federal Funding Accountability and Transparency Act (FFATA);
- (j) Name of Federal awarding agency, pass-through entity, and contact information for awarding official of the Pass-through entity;
- (k) CFDA Number and Name; the pass-through entity must identify the dollar amount made available under each Federal award and the CFDA number at time of disbursement;
- (l) The rest of Section 200.331 is herein incorporated by reference.

6. EMPLOYEE BENEFITS

The Contractor has full responsibility for payment of Workers' Compensation insurance, unemployment insurance, social security, State and federal income tax and any other deductions required by law for its employees.

7. CERTIFICATIONS BY CONTRACTOR

- A. The Contractor expressly agrees to be solely responsible to ensure that the use of monies received under this contract complies with all federal, State and local statutes, regulations and other legal authority, all as modified from time to time, that affect the use of said monies.
- B. The Contractor specifically certifies and assures that it will comply with applicable terms of the following statutes, regulations and executive orders and any amendments thereto:
 - (1) Equal Opportunity
 - (a) Title VI of the Civil Rights Act of 1964 (42 USC §§2000d, et seq.), which prohibits discrimination on the basis of race, color or national origin under any program receiving federal funds. HUD regulations are at 24 CFR, Part 1;
 - (b) Title VIII of the Civil Rights Act of 1968 (42 USC §§3600-3620, 1988), popularly known as the Fair Housing Act;
 - (c) Executive Order 11063 (1962) as amended by Executive Order 12259, which requires equal opportunity in housing. HUD regulations are at 24 CFR, Part 107;
 - (d) Section 109 of the Housing and Community Development Act of 1974, which prohibits discrimination on the basis of race, color, national origin or sex in connection with funds made available pursuant to the Act. Section 109 also prohibits discrimination on the basis of age and disability as provided in:
 - (i) Age Discrimination Act of 1975 (42 USC §§6101, et seq., State Program, Final Rule;



- (ii) Section 504 of Rehabilitation Act of 1973 (29 USC 794); Regulations are at 24 CFR, Part 570.601;
 - (e) Section 3 of the Housing and Urban Development Act of 1968 (12 USC §1701u), which requires that, to the greatest extent feasible, opportunities for training and employment be provided to lower-income persons in the project area and that contracts for work in connection with the project be awarded to businesses in or owned in substantial part by residents of the project area. Regulations are at 24 CFR, Part 135;
 - (f) Executive Order 11246 (1965), which prohibits discrimination on the basis of race, color, religion, sex or national origin and requires affirmative action in connection with federally assisted construction contracts. Regulations are at 24 CFR, Part 100 and 41 CFR, Part 60-1;
 - (g) Section 504 of the Rehabilitation Act of 1973, as amended, which establishes policies, goals and procedures for assuring no otherwise qualified individual with disabilities is, solely on the basis of the disability, denied benefits, subjected to discrimination or excluded from participation in any program or activity receiving federal assistance.
- (2) Labor Standards
- (a) Davis-Bacon Act (40 USC §276a-276a-5), which requires payment of the prevailing wage for the locality to workers on construction contracts over \$2,000. Housing rehabilitation projects of fewer than eight units are exempt. Regulations are at 29 CFR, Part 5. The Contractor further certifies that it shall include in its bidders' packages the U.S. Department of Labor Wage Determination List and a statement that the Contractor and any subcontractors must comply with these wage rates in performance of the work required;
 - (b) Copeland (Anti-Kickback) Act (18 USC §874, 40 USC §176c), which applies to all contracts covered by Davis-Bacon and provides that workers must be paid weekly, with only permissible deductions allowed. Regulations are at 29 CFR, Part 3;
 - (c) Contract Work Hours and Safety Standards Act (40 USC §§327, et seq.), which requires overtime compensation. Regulations are at 29 CFR, Part 5;
- (3) Environment
- (a) National Environmental Policy Act of 1969 (42 USC §§4231, et seq.) (NEPA), and other provisions of law that further the purposes of the Act as specified in HUD Environmental Review Regulations at 24 CFR, Part 58;



- (b) The Contractor's chief executive officer hereby assumes the status of a responsible federal official under NEPA and accepts jurisdiction of the State and federal courts for the purpose of enforcement responsibilities as such an official;
- (c) Finding of Exemption: With regard to the environmental requirements of NEPA and the environmental requirements of related federal authorities, it is the finding of the Contractor that the activities of Administration and Engineering located in 24 CFR 58.34(a) are exempt activities. Upon execution of this contract, the activities of Administration and Engineering require no further environmental review.
- (d) Finding of Categorical Exclusion/Not Subject to 24 CFR 58.5: With regard to the environmental requirements of NEPA and the environmental requirements of related federal authorities, it is the finding of the Contractor that the activity of Purchase of Equipment located in 24 CFR 58.35(b) is a Categorically Excluded activity not subject to 24 CFR 58.5. Upon execution of this contract, this activity requires no further environmental review.
- (4) Acquisition and Relocation
- Uniform Relocation Assistance and Real Property Acquisition Policies Act of 1970, as amended (P.L. 91-646, P.L. 100-17). Section 305 of Title III and Section 210 of Title II require State and local recipients to comply with real property acquisition and relocation requirements set forth in said Act. Regulations are at 49 CFR, Part 24;
- (5) Lead-Based Paint
- Title IV of the Lead-Based Paint Poisoning Prevention Act (42 USC §§4821, et seq.), which prohibits the use of lead-based paint in residences for which federal assistance is provided. Regulations are at 24 CFR, Part 35;
- (6) Debarment and Suspension
- The Contractor certifies it will require certification from subcontractors that neither the subcontractor nor its principals is presently debarred, suspended, proposed for debarment, declared ineligible or voluntarily excluded from participation in any proposal submitted as required by 24 CFR, Part 570.489;
- (7) The Contractor certifies that it is in compliance with 25 O.S. §1313(B).
- (8) The patent rights to any discovery or invention developed as part of the specific activity funded by Community Development Block Grant funds shall belong to the United States Department of Housing and Urban Development.



8. HOLD HARMLESS CLAUSE

- A. The Contractor shall, within limitations placed on such entities by State law, save harmless the State of Oklahoma, its agents, officers and employees from all claims and actions and all expenses defending same that are brought as a result of any injury or damage sustained by any person or property in consequence of any act or omission by the Contractor. The Contractor shall, within limitations placed on such entities by State law, save harmless the State of Oklahoma, its agents, officers and employees from any claim or amount recovered as a result of infringement of patent, trademark or copyright or from any claim or amounts arising or recovered under Workers' Compensation Law or any other law. In any agreement with any subcontractor or any agent for the Contractor, the Contractor will specify that such subcontractors or agents shall hold harmless the State of Oklahoma, its agents, officers and employees for all the herein before-described expenses, claims, actions or amounts recovered.
- B. In the event the Contract or chooses to use volunteer labor to assist in the project activities, the Contractor shall bear any and all liability for any injury or harm caused by the volunteer labor or any harm or injury to the volunteer labor.

9. POLITICAL ACTIVITY

- A. All employees of the Contractor shall observe the limitations on political activities to which they may be subject under the Hatch Act (5 USC §§1501, et seq., 18 USC §595 and any amendments thereto).
- B. No portion of the contract funds may be used for any political activity or to further the election or defeat of any candidate for public office.
- C. No portion of the contract funds may be used for lobbying activities.

10. NO-CONFLICT COVENANT

The Contractor covenants that no officers or employees of any governing board of the Contractor have any interest, direct or indirect, and that none shall acquire any such interest during their tenure or for one year thereafter that would conflict with the full and complete execution of this contract. The Contractor further covenants that in the performance of this contract no person having any such interest will be employed. The Contractor covenants that no employee of ODOC has any interest, direct or indirect, nor has any employee of ODOC received anything of value in connection with this contract.

11. PUBLICATIONS AND OTHER MATERIALS

- A. No material produced in whole or in part under this contract shall be subject to copyright in the United States or any other country. ODOC shall have unrestricted authority to publish, disclose, distribute and otherwise use, in whole or in part, any reports, data or other materials prepared under this contract.
- B. Any publication or other material produced as a result of this contract shall include in a prominent location near the beginning the following statement:



This (type of material) was financed in whole or in part by funds from the U.S. Department of Housing and Urban Development as administered by the Oklahoma Department of Commerce.

12. CONTRACT ADMINISTRATION

- A. The Contractor shall comply with 2 CFR, Part 200 Uniform Administrative Requirements, Cost Principles, and Audit Requirements for Federal Awards except as directed otherwise in writing by ODOC, as they relate to the application, acceptance and use of federal funds and with the Oklahoma Department of Commerce requirements pursuant thereto, which are published in the ODOC CDBG Project Management Guide.
- B. Oklahoma Department of Commerce fully adopts 24 CFR 200.317-326 in full. Units of General Local Government as “sub-recipients” are to follow 2 CFR Part 200.318-326.

13. COMPENSATION TO CONTRACTOR

- A. Funds made available pursuant to this contract shall be used only for expenses incurred during the period funded as specified in Part I for the purposes and activities approved and agreed to by ODOC. No ODOC funds may be used for expenses incurred prior to the contract start date. No ODOC funds may be used for expenses incurred after the contract end date.
- B. ODOC shall disburse funds to the Contractor upon receipt and approval by ODOC of timely, properly executed Requests for Payment of Contract Funds. The Contractor may submit a Request for Payment of Contract Funds as often as necessary to meet its financial obligations. All funds received shall be expended within fifteen (15) days of receipt. No funds shall be disbursed by ODOC when any of the following conditions are present:
 - (1) The latest Monthly Expenditure Report due has not been received and accepted by ODOC. The Contractor is required to submit a Monthly Expenditure Report by the tenth (10th) of the month following the receipt and/or expenditure of funds;
 - (2) Funds are requested for activities not listed on the contract budget or are in excess of the current budget amount for a particular activity.
- C. All requests for funds should be submitted to ODOC during the period funded. A final claim may be submitted no later than sixty (60) days after the final date of the period funded. Said claim will be allowed only for reimbursement of actual expenditures. Any claim submitted after the sixty (60) days may be disallowed by ODOC.
- D. If ODOC determines that payment based on estimated expenditures is resulting in accumulation of excessive balances of cash on hand, ODOC may modify the basis for compensation to the Contractor to effect proper cash management.



E. Payments by Contractor for administrative services will be made in conformance with the following schedule:

<u>Maximum Fee</u> <u>(Cumulative)</u>	<u>Activity</u>
20%	Release of Funds achieved within 120 days.
5%	Release of Funds achieved greater than 120 days.
20%	Construction started within 270 days.
5%	Construction started greater than 270 days.
40%	Construction as project funds are expended (Pro rata).
20%	Submission and acceptance of Final Closeout documents.

F. If a question arises as to the validity of any claim made under this contract and the parties are unable to resolve such question by negotiation, then the Contractor may request a resolution of the question pursuant to the terms of this contract and the administrative procedures available through ODOC rules promulgated pursuant to the Oklahoma Administrative Procedures Act, 75 O. S. §§ 250, et seq.

14. AUTHORITY TO USE GRANT FUNDS (RELEASE OF FUNDS)

A. No costs, with the exception of administration and engineering, shall be incurred until after the Contractor has received written notice from ODOC that the Contractor has satisfied the specific requirements listed herein for release of funds as set forth in the CDBG Project Management Guide. The Contractor may submit a request for Authority to Use Grant Funds for this activity prior to the release of other funded activities.

B. The Contractor shall meet required Authority to Use Grant Funds (Release of Funds) requirements within one hundred twenty (120) days after the beginning of the contract period. In accordance with the CDBG Project Management Guide and other policies as noted below, the Contractor shall submit to ODOC "Request for Authority to Use Grant Funds (Release of Funds)" and required supporting documentation as follows:

- (1) Environmental Review: The Contractor shall complete an Environmental Review for each contract activity with the exception of exempt activities and categorically excluded activities not subject to 24 CFR 58.5, i.e., administration, engineering and purchase of equipment;
- (2) Leverage Commitment: The Contractor shall submit Certification of Leverage, certifying that leverage funds are available and identifying the source and amount in accordance with approved application.
- (3) Insurance and Bonding: The Contractor shall submit evidence of:



- (a) General liability insurance covering the funded activities; and
- (b) Bonding of all officials who are responsible for financial transactions relating to this contract;
- (4) Anti-Displacement Plan: The Contractor must adopt and submit an Anti-Displacement Plan in accordance with ODOC CDBG Project Management Guide;
- (5) Other: Special conditions in accordance with this contract and ODOC CDBG Project Management Guide as follows:
 - (a) Contractor has met any special conditions specified in Section II of this contract;
 - (b) Contractor's audit has been accepted and approved by ODOC;
 - (c) Contractor has attended a CDBG training session.
- (6) A review committee will determine de-obligation of CDBG funding if the project has NOT satisfactorily been completed and Release of Funds has NOT been obtained. This review committee may be composed of ODOC Community Development staff including: CDBG Planner, Director of Programs (Planning and Monitoring), and the Division Director.

15. PROCUREMENT

- A. Procurement, management and disposition of property acquired with contract funds shall be governed by federal and State law, and as directed by ODOC in the CDBG Project Management Guide. Applicable State laws include the Public Competitive Bidding Act of 1974, 61 O. S. §§101, et seq.
- B. Materials acquired for construction purposes shall be deemed real property once they have become part of the improvement.

16. RECORDS, REPORTS, DOCUMENTATION

- A. The Contractor shall maintain records and accounts, including property, personnel and financial records that properly document and account for all project funds. Specific types and forms of record are required in the ODOC CDBG Project Management Guide.
- B. The Contractor the Closeout Documentation or until all monitoring/audit findings have been resolved, whichever is later. All records and accounts shall be made available on demand to the Oklahoma State Auditor and Inspector, HUD, the Comptroller General and ODOC, its agents and designee for inspection and use in carrying out its responsibilities for administration of funds.
- C. The Contractor will submit to ODOC documentation of local leverage funds used for the project in such form and at such times as required by ODOC.



- D. The Contractor has not paid, given or donated or agreed to pay, give or donate to any officer or employee of the State of Oklahoma any money or other thing of value, either directly or indirectly in the procuring of this contract.

17. CLOSING OUT OF CONTRACT

- A. The Contractor shall promptly return to ODOC any funds received under this contract that are not obligated as of the final date of the period funded. Funds shall be considered obligated only if goods and services have been received as of the final date of the period funded.
- B. ODOC may unilaterally modify this contract to subtract the total amount of funds not obligated by the Contractor as of the final date of the period funded.
- C. The Contractor cannot close out the contract until the project is completed and all monitoring issues have been resolved and approved by ODOC.
- D. The Contractor shall submit closeout documents in accordance with ODOC Project Management Guide no later than sixty (60) days after the final date of the period funded or upon completion of the project, whichever comes first.

18. AUDIT, DISALLOWED COSTS

- A. The Contractor shall comply with ODOC's Audit Policies and Audit Procedures, which are incorporated herein and made apart hereof.
- B. The Contractor shall provide ODOC with timely copies of reports on any audits that include funds received from ODOC.
- C. In the event an audit results in the determination that the Contractor has expended contract funds on unallowable costs, the Contractor shall reimburse ODOC in full for all such costs.

19. PROGRAM INCOME

The Contractor shall account to ODOC for all Program Income resulting from this agreement, as provided in 24 CFR 570.489(e) and any amendments thereto. Disposition of Program Income will be determined by ODOC.

20. INTERPRETATION, REMEDIES

- A. In the event the terms or provisions of this contract are breached by either party or in the event a dispute shall arise between the parties regarding the meaning, requirements or interpretation of the terms and provisions of this contract, then such breach or dispute shall be resolved pursuant to the terms of this contract and the administrative procedures available through ODOC rules promulgated pursuant to the Oklahoma Administrative Procedures Act, 75 O.S. §§250, et seq.
- B. Neither forbearance nor payment by ODOC shall be construed to constitute waiver of any remedies for any default or breach by the Contractor that exists then or occurs later.



- C. This contract shall be construed and interpreted pursuant to Oklahoma law.
- D. The Subgrantee Recipient may appeal any ODOC monitoring finding or ODOC decision by following procedures outlined in Oklahoma Administrative Code, Title 150, Chapter 1, subchapter 11.

21. TERMINATION OR SUSPENSION

- A. This contract may be terminated or suspended in whole or in part at any time by written agreement of the parties.
- B. This contract may be terminated or suspended by ODOC, in whole or in part, for cause, after notice and an opportunity for Contractor to present reasons why such action should not be taken. Procedures for such a process shall be in accordance with the General Rules or Practice and Procedure of the Department. Grounds constituting cause include but are not limited to:
 - (1) The Contractor fails to meet the requirements for Authority to Use Grant Funds within one hundred twenty (120) days after the beginning of the contract period;
 - (2) The Contractor fails to commence actual construction or otherwise begin implementation of the funded project within two hundred seventy (270) days from the start date of the contract;
 - (3) The Contractor fails to comply with provisions of this contract or with any applicable laws, regulations, guidelines or procedures, including ODOC policies and issuances, or is unduly dilatory in executing its commitments under this contract;
 - (4) Purposes for the funds have not been or will not be fulfilled or would be illegal to carry out;
 - (5) The Contractor has submitted incorrect or incomplete documentation pertaining to this contract;
 - (6) The Contractor is unduly dilatory in executing its commitments under a prior contract with ODOC, including, but not limited to submission of any audits due, resolution of audit findings and monitoring results.
- C. In the event of termination or suspension, the Contractor shall be entitled to payment for otherwise valid and allowable obligations incurred in good faith prior to notice of such action and to reimbursement for reasonable and necessary expenses. The Contractor shall reduce to the minimum possible obligations, prepaid expenses and other costs.
- D. The Contractor shall not be relieved of liability to ODOC for damages sustained by ODOC by virtue of any breach of this agreement by the Contractor. ODOC may withhold payments due under this agreement pending resolution of the damages.



- E. ODOC reserves the right to cancel, suspend or terminate this contract without notice, in the event the Contractor has outstanding issues relating to another contract with ODOC. These issues include but are not limited to:
- (1) Failure to timely submit any required reports;
 - (2) Failure to respond to any communication from ODOC; and
 - (3) Failure to abide by any programmatic or ODOC requirements.

22. SEVERABILITY CLAUSE

If any provision under this contract or its application to any person or circumstance is held invalid by any court of competent jurisdiction, such invalidity does not affect any other provision of this contract or its application that can be given effect without the invalid provision or application.

**Certification Regarding Lobbying
Certification for Contracts, Grants, Loans,
And Cooperative Agreements**

The undersigned certifies, to the best of his or her knowledge and belief, that:

1. No Federal appropriated funds have been paid or will be paid, by or on behalf of the undersigned, to any person for influencing or attempting to influence an officer or employee of an agency, a Member of Congress, an officer or employee of Congress, or an employee of a Member of Congress in connection with the awarding of any Federal contract, the making of any Federal grant, the making of any Federal loan, the entering into of any cooperative agreement, and the extension, continuation, renewal, amendment, or modification of any Federal contract, grant, loan, or cooperative agreement.
2. If any funds other than Federal appropriated funds have been paid or will be paid to any person for influencing or attempting to influence an officer or employee of any agency, a Member of Congress, an Officer or employee of Congress, or an employee of a Member of Congress in connection with this Federal contract, grant, loan, or cooperative agreement, the undersigned shall complete and submit Standard Form-LLL, "Disclosure Form to Report Lobbying," in accordance with its instructions.
3. The undersigned shall require that the language of this certification be included in the award documents for all sub awards at all tiers (including subcontracts, sub grants and contracts under grants, loans, and cooperative agreements) and that all subrecipients shall certify and disclose accordingly.

This certification is a material representation of fact upon which reliance was placed when this transaction was made or entered into. Submission of this certification is a prerequisite for or entering into this transaction imposed by Section 1352, Title 31, U.S. Code. Any person who fails to file the required certification shall be subject to a civil penalty of not less than \$10,000 and not more than \$100,000 for each such failure.



August 3, 2020

David Berrong, Mayor
City of Clinton
415 Gary Blvd.
Clinton, OK 73601

Dear Mayor Berrong:

The Oklahoma Department of Commerce/Community Development (ODOC/CD) has completed a review and analysis of the City of Clinton's Community Development Block Grant (CDBG) request for a Water/Wastewater Construction Award. ODOC/CD is pleased to inform you that the project has been approved for funding in the amount of \$450,000.

To officially accept this award:

- The **Authorized Official** must log-in to OKGrants (<https://grants.ok.gov>); or click the link above.
- Once signed-in, proceed to "My Tasks " and click on the contract that says "Contract Signatures Required"; which will take you to the "Application Menu."
- At "Application Menu," select "**View, Edit, and Complete Forms.**"
- In the **Award Section** (bottom of page) select "**Contract Part I.**"
- Review the **Contract Part I** and click on the link to **Part II** and print off for your records. When ready to accept, follow the next step.
- Next, **click on the radio-button** to "Certify authorization to sign the document."
- **Type in Name and Date.**
- Once completed, **click save button (top of page).**
- Next, click on the **Print Version** button and print out the form for your records. You can also do this step once it is executed by ODOC. Should this contract ever be modified, this information will not be retained.
- Once saved, click on the contract title next to "Document Information" (*Contract title will highlight when mouse is moved over it*) located on same page above "Instructions" to take you back to "Application Menu".
- Once back in "Application Menu", click the "**Apply Status**" button underneath "Change the Status" and then click the button of "Contract Signatures Submitted" to change the status.

Should this award be accepted, it will be memorialized as the following contract number **17852 CDBG 20**.

Important Information Concerning Bank Accounts and Electronic Funds Transfer (EFT):

The award recipient (grantee) requests partial pay advances for the above referenced award through the OKGrants system. The Oklahoma Department of Commerce will then request payment through PeopleSoft, the accounting system utilized by the State of Oklahoma. The Office of Management and Enterprise Services (OMES) maintains all payee information, including banking information. It is the **grantee's responsibility** to contact the OMES Vendor Maintenance Division to update any changes to grantee's financial information on file or if a new account needs to be established. Incorrect information will delay your payment. The OMES Vendor Maintenance contact information is as follows:

Vendor Registration

Victoria Baker

405-522-3093

victoria.baker@omes.ok.gov

Vendor File Maintenance

vendor.form@omes.ok.gov

Vendor Remittance Updates

update to remittance contact for vendor payment notification.

remittance@omes.ok.gov

OMES Service Desk

405-521-2444 or toll-free 866-521-2444

servicedesk@omes.ok.gov

We look forward to working with you in the coming months. Should you have any questions, please contact Karen Adair at 405-815-5363 or Karen.Adair@okcommerce.gov.

Sincerely,



Marshall Vogts, Director
Community Development

Cc: Clyde Morgan



Agenda Commentary

Item Title/ Subject: Inter-Local Agreement with Custer County

Staff Source: Gene McCullough, Acting City Manager

Date: September 1, 2020

History/Background Information: The City of Clinton and Custer County regularly enter into inter-local agreements for the betterment of both parties when it is feasible.

Subject Summary: The Custer County Courthouse has requested use of the Frisco Conference Center for COVID-safe handling of upcoming trials. The trials cannot be safely administered at their current facilities.

Recommendation: Approve the inter-local agreement with Custer County.

Price/Cost: \$40/day to cover janitorial/sanitation costs

INTER-LOCAL AGREEMENT

WHEREAS, on March 11, 2020, the World Health Organization (WHO) declared the coronavirus COVID-19 disease to be a pandemic; and

WHEREAS, on March 13, 2020, the President of the United States declared a National Emergency; due to the COVID-19 Virus pandemic; and

WHEREAS, on March 15, 2020, the Governor of the State of Oklahoma declared an emergency caused by the impending threat of COVID-19 to the people of this State and the public's peace, health and safety; and

WHEREAS, on March 16, 2020 the Supreme Court and Court of Criminal Appeals for the State of Oklahoma canceled all jury terms;

WHEREAS, the Governor's statewide emergency declaration and that of the Supreme Court and Court of Criminal Appeals has been renewed and extended numerous times and remains in effect; and

WHEREAS, on April 29, 2020 the Supreme Court and the Court of Criminal Appeals modified their Joint Order and required that all Jury Trials be rescheduled for a jury docket after July 31, 2020; and

WHEREAS, the April 29, 2020 Joint Order required the continued use of all available means to ensure the health of all participants in any court proceedings, limited the number of individuals in specified spaces and required social distancing; and

WHEREAS, it is the duty of the Commissioners of Custer County and City Council of the City of Clinton to protect the health and safety of the City and its inhabitants, to preserve the peace and administer justice, and to provide emergency functions; and

WHEREAS, it is necessary in the administration of justice and that Jury Trials be conducted and that they be conducted in the most efficient and health conscience manner.

NOW THEREFORE:

The Commissioners of Custer County, Oklahoma and the City Council for The City of Clinton, Oklahoma agree that the County may utilize the Frisco Center, located at 101 S 4th St, Clinton, OK, for the purposes of conducting Jury Trials.

Duration: This Interlocal Agreement shall initially cover the 2020 Fall Jury Term, but may be extended as needed due to the COVID-19 pandemic. In order to allow for scheduling, County must notify City 60 day in advance of any future Jury Term. This Agreement shall terminate when the COVID-19 emergency is declared by the Governor of the State of Oklahoma to be over.

Use of Space: County shall be entitled to use (1) all common areas, (2) one half of the Exhibit Hall, and (3) an extended meeting room, for the purpose of conducting Jury Trials. The Trial Judge and Frisco Center personal shall determine the most appropriate extended meeting room to utilize for the purposes of the Jury Trial prior to each jury trial.

Consideration: As consideration for the use of the space, County shall reimburse City \$20 per room, per day utilized, in order to offset the cleaning costs. City shall invoice County within 30 days of the completion of the applicable Jury Term.

Dated this ___ day of _____, 2020.

CITY OF CLINTON,
OKLAHOMA

CUSTER COUNTY, OKLAHOMA

David Berrong, Mayor

County Commissioner

ATTEST:

County Commissioner

Debra Blanchard,
Acting City Clerk

County Commissioner

ATTEST:

Secretary